

# ULTRASUITE® + STRUCTURE

## OPERATING ROOM DIFFUSER SYSTEM WITH INTEGRATED LED LIGHTING AND ALUMINUM STRUCTURAL SUPPORT EXAMPLE SYSTEM FOR A TRADITIONAL OR

### FEATURES:

- LAMINAR FLOW DIFFUSER ARRAY WITH INTEGRATED HIGH-PERFORMANCE LED LIGHTS INSIDE EACH INDIVIDUAL MODULE AND HSS STRUCTURE FULLY CUSTOMIZABLE TO MATCH THE DEMANDING AND OFTEN CROWDED MODERN HOSPITAL AND CLEANROOM CEILING LAYOUTS
- OPTIONAL PERIMETER HGWC WELDED CEILING GRID SUPPORTS ACCESS PANELS AND FLUSH-MOUNT PANELS FOR EQUIPMENT BOOM INTEGRATION
- UL 1598 CERTIFIED, AIR-HANDLING LUMINAIRE

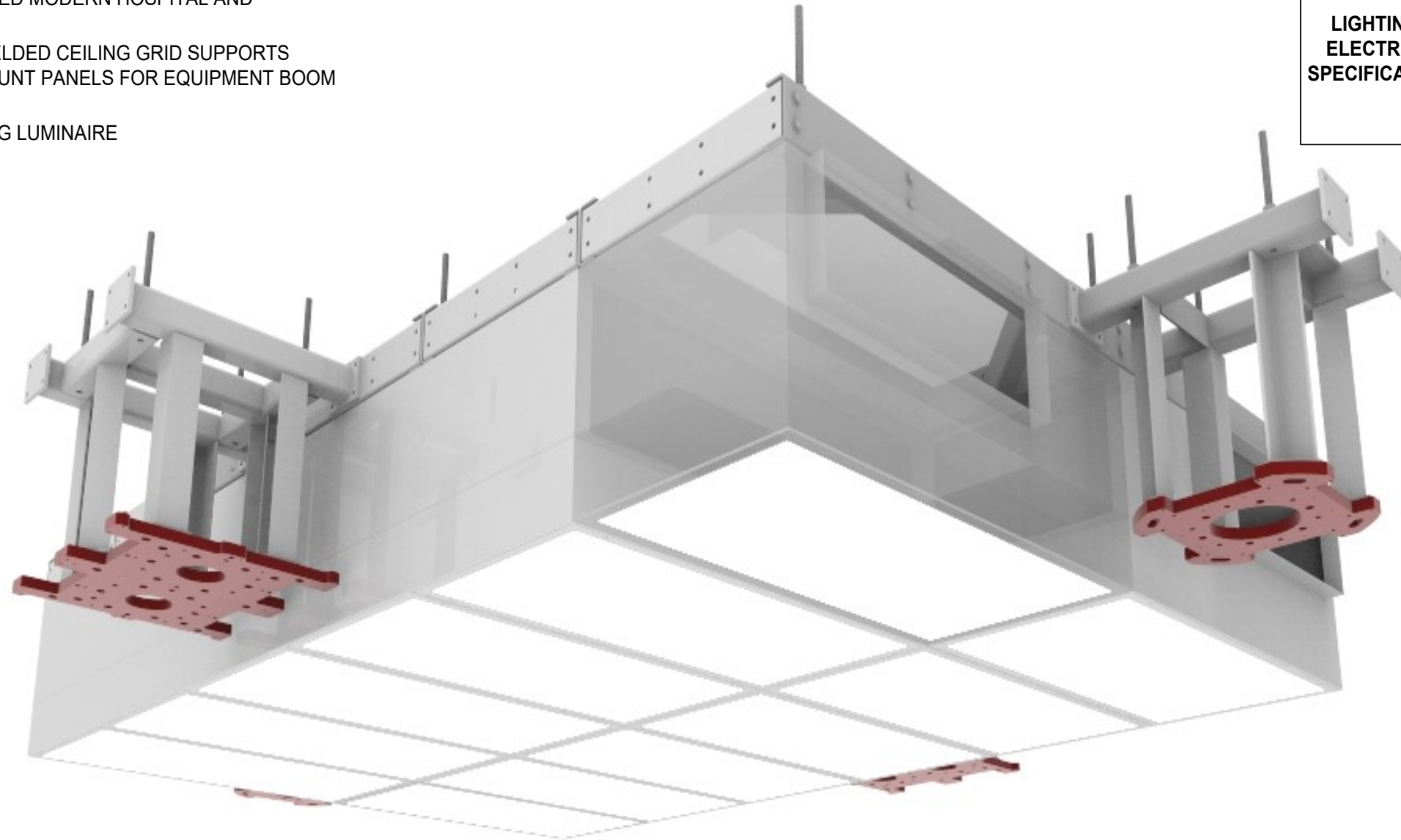

EXAMPLE SYSTEM		
AIRFLOW	2400	CFM
	20	ACH
LIGHTING & ELECTRICAL SPECIFICATIONS	5000K	COLOUR TEMPERATURE
	95	CRI
	100% TO 1%	DIMMING
0-10V		
	277	INCOMING VOLTAGE



**PRICE** | **CRITICAL ENVIRONMENTS**

Project:

USASA-2-1

276328

Revision: 0

01-12-2024

# ULTRASUITE<sup>®</sup> + STRUCTURE

## OPERATING ROOM DIFFUSER SYSTEM WITH INTEGRATED LED LIGHTING AND ALUMINUM STRUCTURAL SUPPORT 3D INTERACTIVE MODEL - TRADITIONAL OR

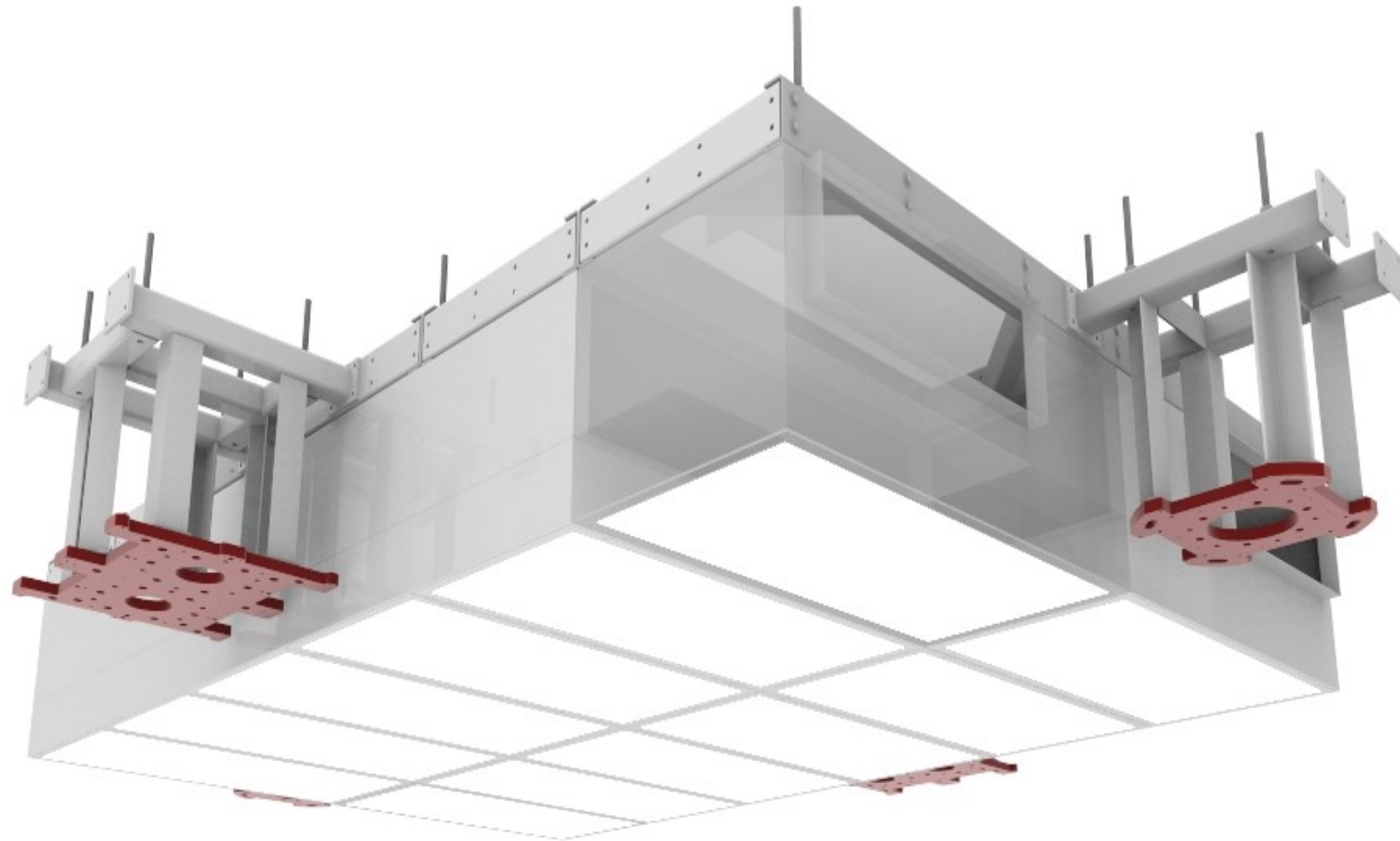

ORDER OF INSTALLATION  
(CLICK BUTTONS TO TOGGLE VIEWS)

ULTRASUITE +STRUCTURE  
(View A)

ULTRASUITE +STRUCTURE  
(View B)

ULTRASUITE +STRUCTURE  
(View C)

HGWC CEILING GRID  
(View A)

HGWC CEILING GRID  
(View B)

CP-SCF CEILING PANELS

CP-SC CEILING PANELS

FINAL INSTALLATION

CLICK IMAGE TO  
ACTIVATE 3D PDF



**price** | **CRITICAL ENVIRONMENTS**

Project:

276328

Revision: 0

01-12-2024

- USE THE SCROLL WHEEL TO ZOOM
  - HOLD DOWN THE LEFT MOUSE BUTTON TO ROTATE
  - HOLD DOWN CTRL AND LEFT MOUSE BUTTON TO MOVE
- BOOM SUPPORT AND STRUCTURE PROVIDED BY PRICE  
BOOM AND BOOM PLATE PROVIDED AND INSTALLED BY OTHERS

# ULTRASUITE® + STRUCTURE

## OPERATING ROOM DIFFUSER SYSTEM WITH INTEGRATED LED LIGHTING AND ALUMINUM STRUCTURAL SUPPORT REFLECTED CEILING PLAN - TRADITIONAL OR

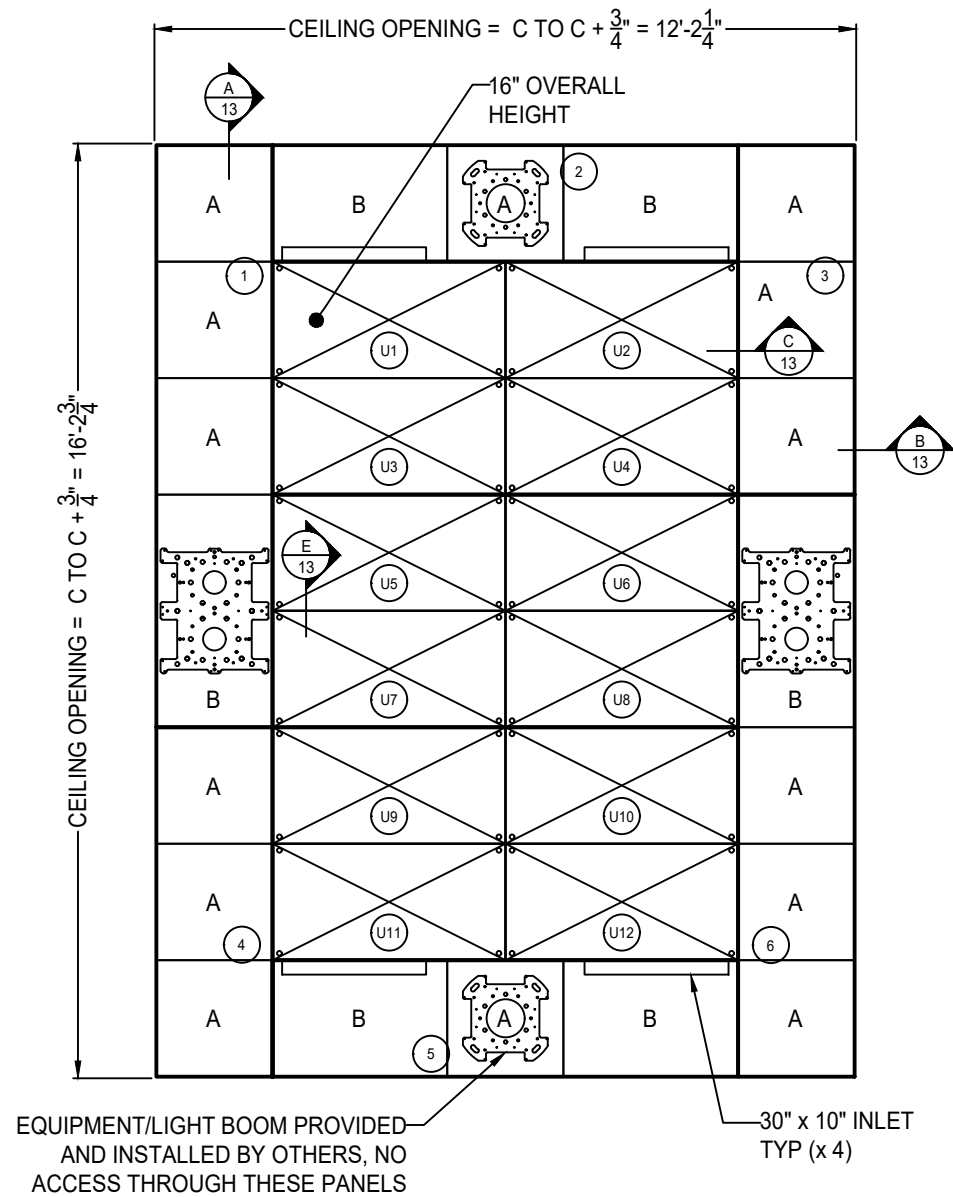

USA AREA = 96 sq. ft.    HGWC AREA = 96 sq. ft.

24 x 48 (x12)	A: 24 x 24 (x12) B: 24 x 36 (x4)	A: 24 x 24 (x2) B: 24 x 48 (x2)

## ASHRAE 170-2021 TABLE COVERAGE VERIFICATION - TRADITIONAL OR

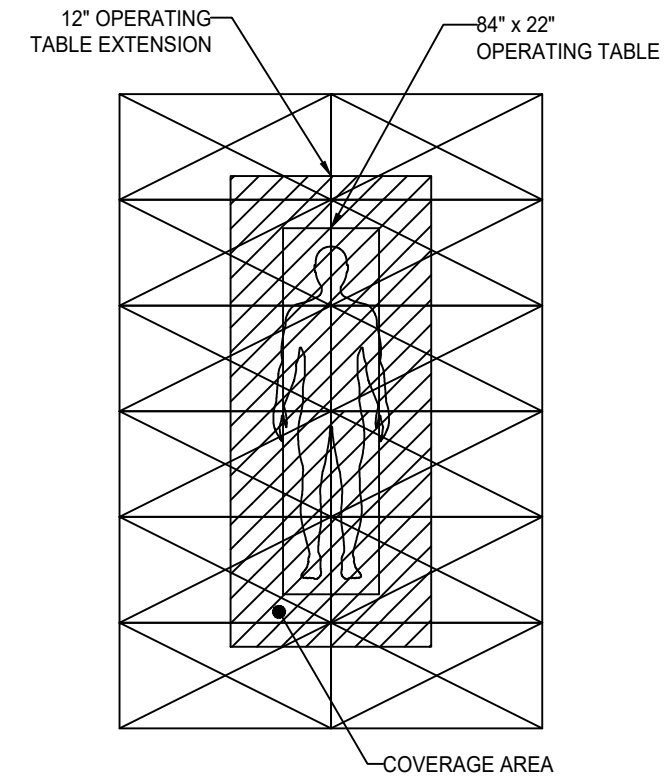

**THIS LAYOUT COMPLIES WITH ASHRAE 170-2021 7.4.1.b.**

ASHRAE 170-2021 7.4.1.a. COMPLIANCE AIRFLOW RANGE	ASHRAE 170-2021 7.4.1.b. COMPLIANCE
2400 - 3360 CFM BASED ON 96 SQFT	0% OF THE 12" OPERATING TABLE EXTENSION USED FOR NON DIFFUSER USES

### ASHRAE 170-2021

7.4.1.a. - THE AIRFLOW SHALL BE UNIDIRECTIONAL, DOWNWARDS, AND THE **AVERAGE VELOCITY OF THE DIFFUSERS SHALL BE 25 TO 35 CFM/SQFT** (127 TO 178 L/S/QM). THE DIFFUSERS SHALL BE CONCENTRATED TO PROVIDE AN AIRFLOW PATTERN OVER THE PATIENT AND SURGICAL TEAM.

7.4.1.b. - THE COVERAGE AREA OF THE PRIMARY SUPPLY DIFFUSER ARRAY SHALL EXTEND A MINIMUM OF 12 IN. (305 mm) BEYOND THE FOOTPRINT OF THE SURGICAL TABLE ON EACH SIDE. WITHIN THE PORTION OF THE PRIMARY SUPPLY DIFFUSER ARRAY THAT CONSISTS OF **AN AREA ENCOMPASSING 12 IN. (305mm) ON EACH SIDE OF THE FOOTPRINT OF THE SURGICAL TABLE, NO MORE THAN 30% OF THIS PORTION OF THE PRIMARY SUPPLY DIFFUSER ARRAY AREA SHALL BE USED FOR NON DIFFUSER USES** SUCH AS LIGHTS, GAS COLUMNS, EQUIPMENT BOOMS, ACCESS PANELS, SPRINKLERS, ETC.

- B12 STANDARD WHITE FINISH
- PANEL CUTOUTS FOR BOOMS DONE IN FIELD BY OTHERS
- THE CEILING IS FACTORY PREMANUFACTURED TO SIZES AND TOLERANCE  $\pm \frac{1}{16}$ "
- SITE ADJUSTMENTS TO PERIMETER SOFFITS AND/OR DRYWALL MAY BE REQUIRED AND ARE THE RESPONSIBILITY OF THE INSTALLER
- ASHRAE 170 VERIFICATION IS SHOWN TO ASSIST IN PROJECT COORDINATION. FINAL ASHRAE 170 COMPLIANCE, AS WELL AS COMPLIANCE WITH ALL APPLICABLE LOCAL CODES AND REQUIREMENTS REMAINS THE RESPONSIBILITY OF THE EOR OR INSTALLER ON THE PROJECT



Project:

USASA-2-1

276328

Revision: 0

01-12-2024

# ULTRASUITE® + STRUCTURE

## OPERATING ROOM DIFFUSER SYSTEM WITH INTEGRATED LED LIGHTING AND ALUMINUM STRUCTURAL SUPPORT PHOTOMETRIC ANALYSIS - TRADITIONAL OR

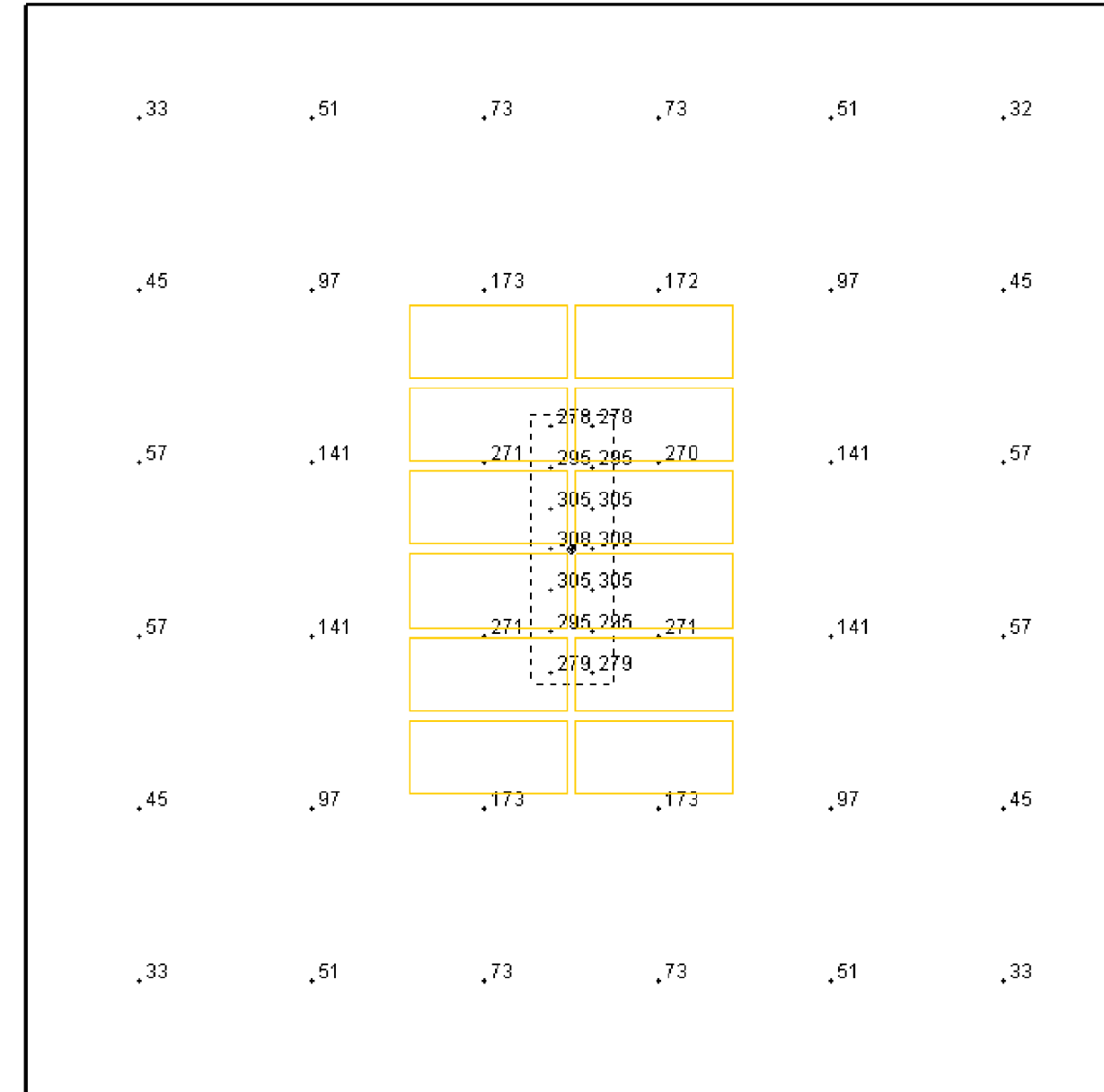
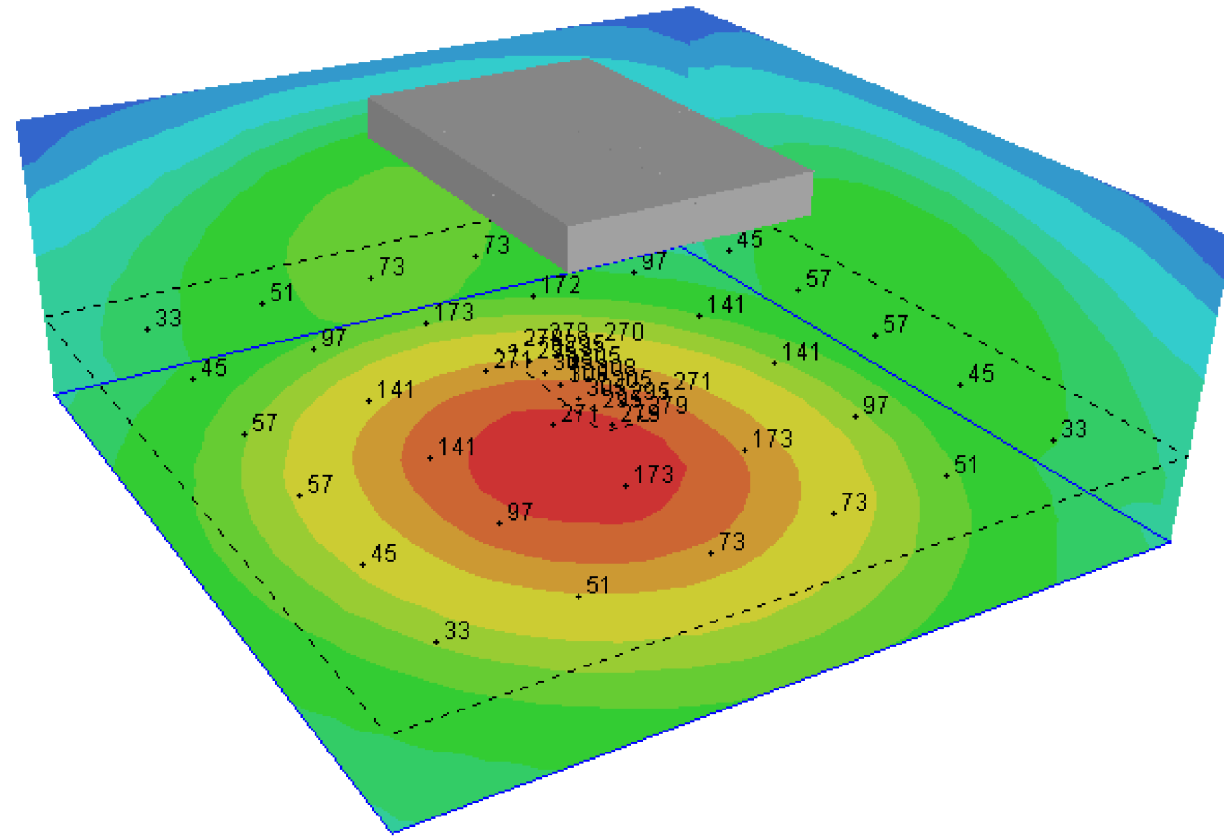

OPERATING TABLE		OPERATING AREA	
MAXIMUM	308 fc	MAXIMUM	271 fc
AVERAGE	295 fc	AVERAGE	104 fc

LUMINAIRE HEIGHT: 10 FT  
CALCULATION ZONE: 3 FT



Project:

276328

Revision: 0

01-12-2024

- PHOTOMETRIC ANALYSIS BASED ON A 3' CALCULATION ZONE, 720 ROOM SQFT & 10' CEILING HEIGHT.
- ANSII/IES RP-29-16 RECOMMENDS 3000 LUX (279 FC) AT THE OPERATING TABLE
- THE CALCULATED VALUES REFLECT ADDITIONAL SPACE LIGHTING BY OTHERS.
- LIGHTING ANALYSIS HAS BEEN PERFORMED USING THIRD PARTY LAB TESTED .IES FILES.
- THIS LAYOUT REFLECTS TWO ROWS OF 5000K, 90+ CRI LEDS PER MODULE. A THIRD ROW, HIGH OUTPUT OPTION IS AVAILABLE.
- LIGHTING CALCULATIONS ARE ESTIMATED USING BEST PRACTICE AND MAY DIFFER SLIGHTLY FROM ACTUAL FIELD CONDITIONS.

# ULTRASUITE® + STRUCTURE

## OPERATING ROOM DIFFUSER SYSTEM WITH INTEGRATED LED LIGHTING AND ALUMINUM STRUCTURAL SUPPORT

○ URDC ULTRA REMOTE DRIVER CABINETS - SINGLE DIMMING ZONE (100 TO 1% DIMMING) - TRADITIONAL OR

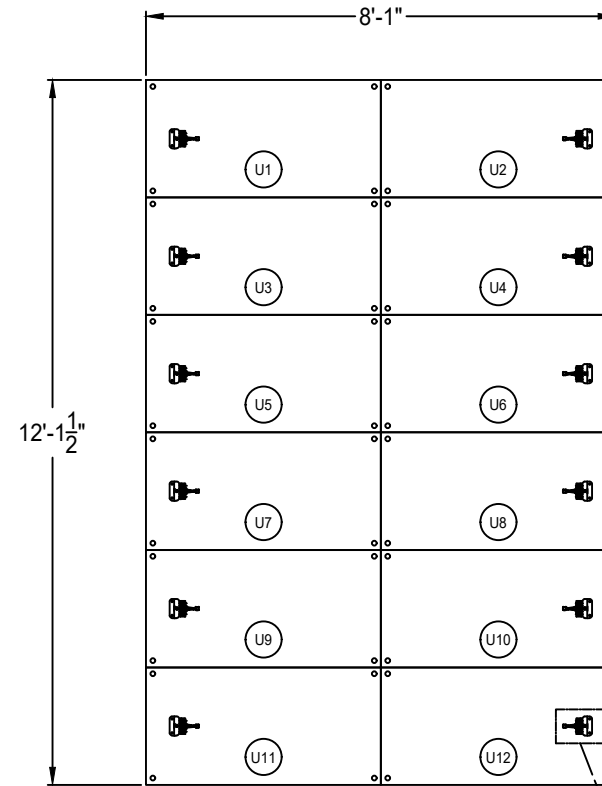
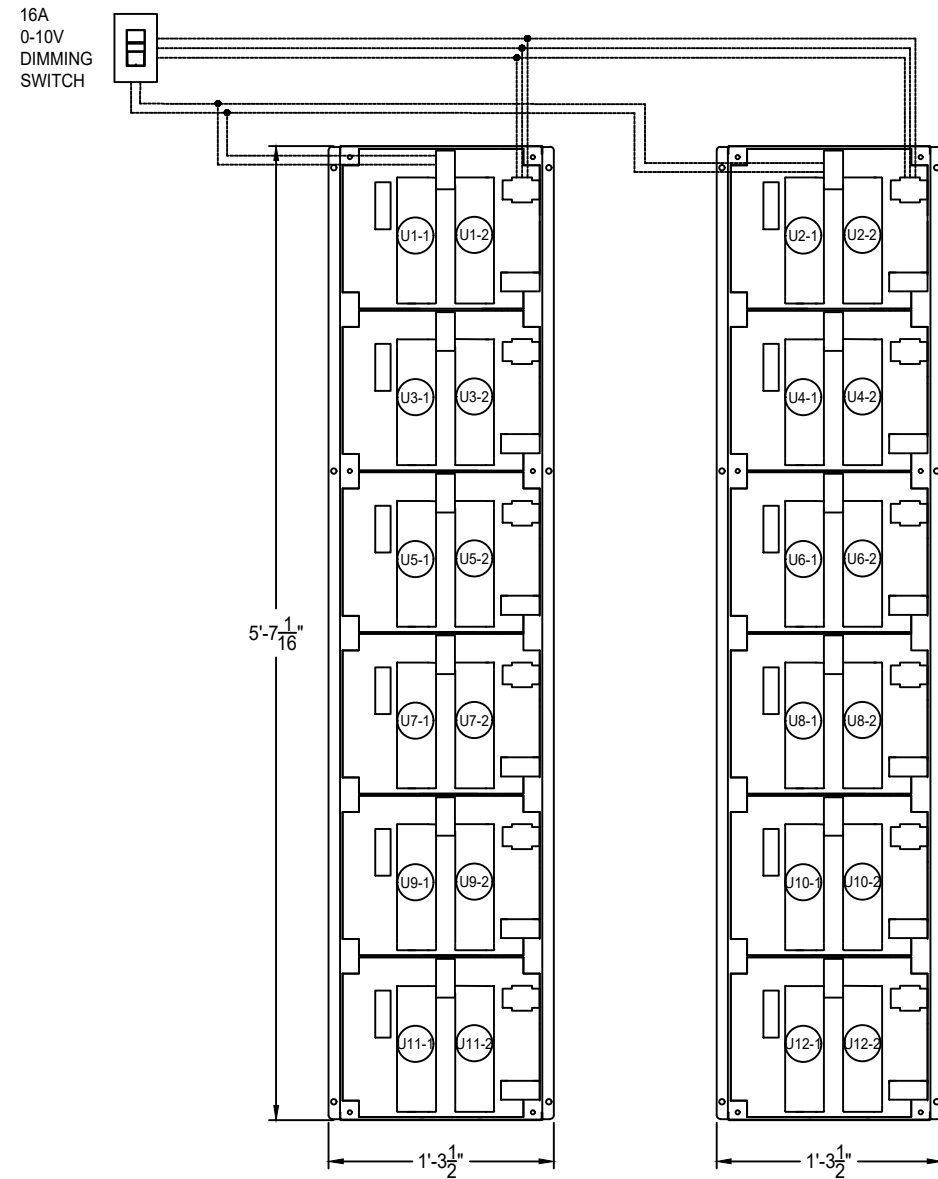

**CABINET 1 - 1 OF 2 - CONTROLS 6 MODULES WITH 12 DRIVERS**

DRIVER TAG	LED WATTAGE	DRIVER TAG	LED WATTAGE
U1-1	88	U1-2	88
U3-1	88	U3-2	88
U5-1	88	U5-2	88
U7-1	88	U7-2	88
U9-1	88	U9-2	88
U11-1	88	U11-2	88
<b>TOTAL WATTAGE:</b>	<b>AC CURRENT:</b>		
1056	4.8A/277VAC		

**CABINET 2 - 2 OF 2 - CONTROLS 6 MODULES WITH 12 DRIVERS**

DRIVER TAG	LED WATTAGE	DRIVER TAG	LED WATTAGE
U2-1	88	U2-2	88
U4-1	88	U4-2	88
U6-1	88	U6-2	88
U8-1	88	U8-2	88
U10-1	88	U10-2	88
U12-1	88	U12-2	88
<b>TOTAL WATTAGE:</b>	<b>AC CURRENT:</b>		
1056	4.8A/277VAC		



EACH STANDARD MODULE COMES WITH TWO ROWS OF LEDS THAT EACH REQUIRE ONE (+ & -) LOW VOLTAGE FIELD CONNECTION AND ARE NOTED BY A "UX-X" LABEL. A THIRD ROW, HIGH OUTPUT OPTION IS AVAILABLE IF REQUIRED.

EACH STANDARD MODULE COMES WITH 2 ROWS OF LED LIGHTS AND EACH ROW OF LIGHTS IS NOTED BY A "UX-X" LABEL. THE "UX" CORRESPONDS TO AN INDIVIDUAL MODULE REFERENCED IN THE RCP AND THE "-1" AND "-2" CORRESPONDS TO THE ROW OF LEDS FOR THAT MODULE. EACH "UX-X" LABEL CORRESPONDS TO ONE (+ & -) LOW VOLTAGE WIRE TO BE FIELD CONNECTED TO URDC DRIVER CABINET AS PER THE MATCHING LABELS. EACH 100W DRIVER CAN POWER 1 ROW OF LEDS (ONE HALF OF A MODULE) AND EACH 600W DRIVER CAN CONTROL 6 ROWS OF LEDS (3 MODULES)

EACH MODULE COMES WITH A TOP MOUNTED TERMINAL BLOCK ENCLOSURE (COVER NOT SHOWN) FOR LOW VOLTAGE FIELD CONNECTIONS. QUICK CONNECT FITTING IS SEALED THROUGH PLENUM AND ALL INTERNAL WIRING IS COMPLETED IN THE FACTORY. EACH ROW OF LEDS REQUIRES ONE (+&-) LOW VOLTAGE FIELD CONNECTIONS (TWO PER MODULE)

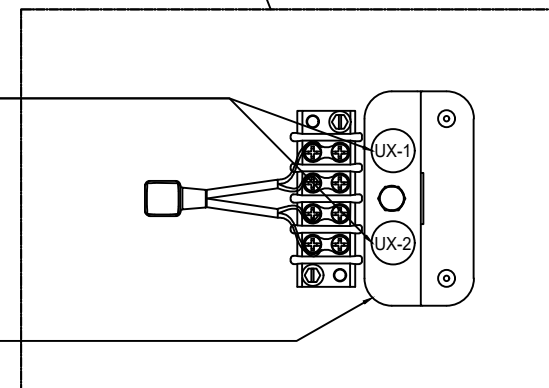

Project:

276328

Revision: 0

01-12-2024

• INSTALLATION WORK AND ELECTRICAL WIRING MUST BE COMPLETED BY A CERTIFIED ELECTRICIAN AND/OR QUALIFIED PERSON(S) IN ACCORDANCE WITH APPLICABLE ELECTRICAL CODES AND STANDARDS



# ULTRASUITE® + STRUCTURE

## OPERATING ROOM DIFFUSER SYSTEM WITH INTEGRATED LED LIGHTING AND ALUMINUM STRUCTURAL SUPPORT STRUCTURAL DETAILS - ISOMETRIC VIEW - TRADITIONAL OR

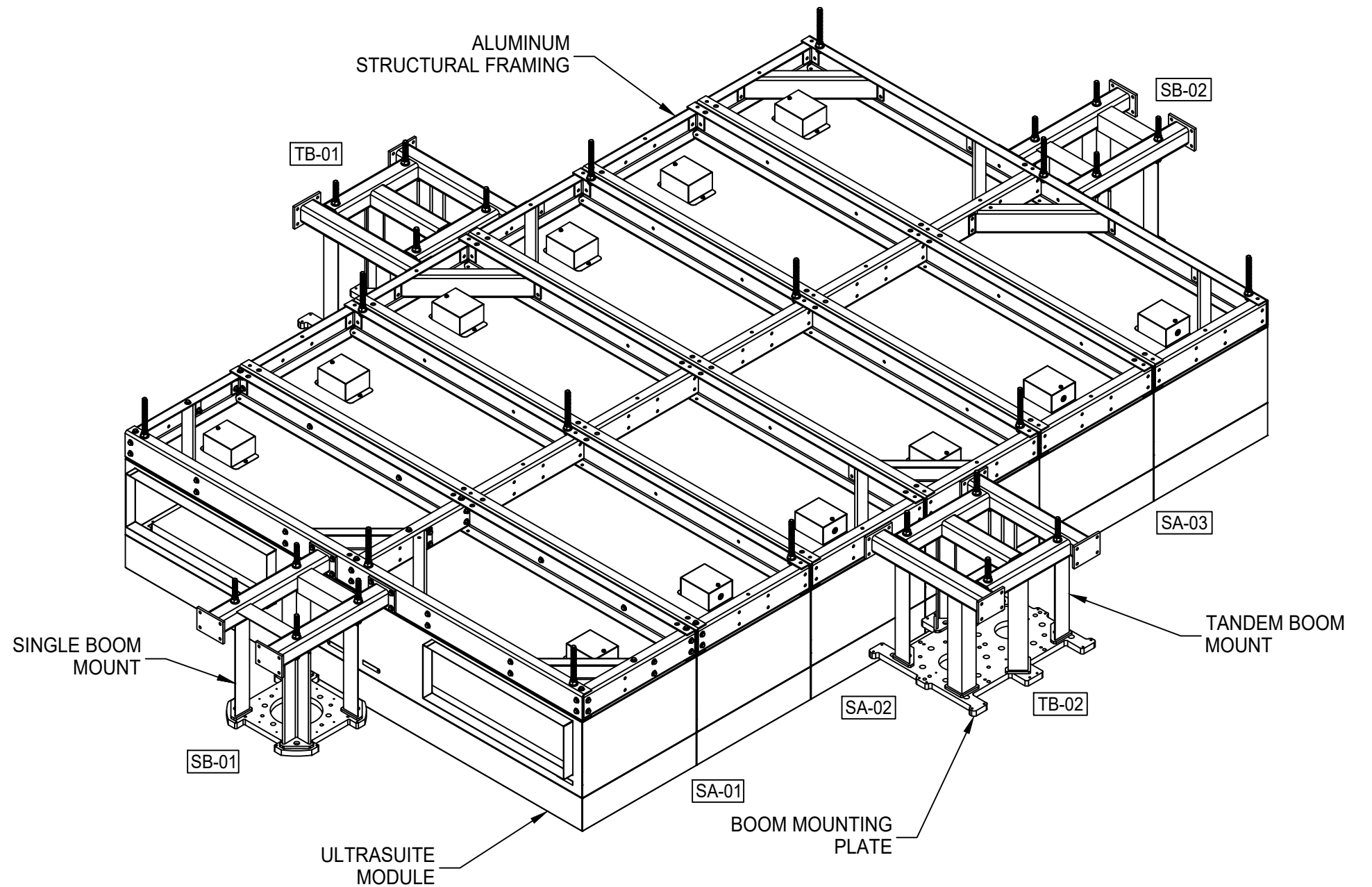

- THE PROJECT ADDRESS IS 20 CRESTRIDGE DRIVE, SUWANNEE, GA 30024.
- THE USASA SUSPENDED FRAME IS DESIGNED FOR THE FOLLOWING CRITERIA:
  - SEISMIC PARAMETERS:  $I_p=1.5$   $S_s = 0.197$   $S_{DS} = 0.121$   $S_1 = 0.087$
  - SINGLE BOOM MOUNT LOADS: 1,100 lbf AND 5,650 ft-lbs
  - TANDEM BOOM MOUNT LOADS: 2,200 lbf AND 11,300 ft-lbs
- THE FOLLOWING GRADES OF MATERIAL WILL BE USED IN THE CONSTRUCTION OF THIS SUSPENDED SYSTEM:
  - ULTRASUITE MODULES: ASTM A653 CS TYPE B
  - ALUMINUM COLD FORMED MEMBERS: 5052-H32 ALUMINUM ALLOY
  - STRUCTURAL BOLTS: SAE J429 GR. 5, ZINC-PLATED
  - BOOM MOUNTS
    - HSS BEAMS: ASTM A500 GR. B OR C
    - ROLLED ANGLES: A36 OR EQUIVALENT
    - STRUCTURAL PLATES: A36 OR EQUIVALENT
- THREADED ROD HANGERS: 5/8" THREADED ROD (PROVIDED BY OTHERS) ( $F_{YMIN} = 36KSI$ )  
(NOTE: ANCHOR DESIGN AND EMBEDMENT BY OTHERS, BASED ON LOADS PROVIDED AFTER STRUCTURAL ANALYSIS)
- BOOM MOUNT STRUCTURAL STEEL TO BE PAINTED WITH A CORROSION RESISTANT PAINT SYSTEM.

**PRICE** | **CRITICAL ENVIRONMENTS**

Project:

276328

Revision: 0

01-12-2024

# ULTRASUITE<sup>®</sup> + STRUCTURE

## OPERATING ROOM DIFFUSER SYSTEM WITH INTEGRATED LED LIGHTING AND ALUMINUM STRUCTURAL SUPPORT STRUCTURAL DETAILS - SUSPENSION LAYOUT - TRADITIONAL OR

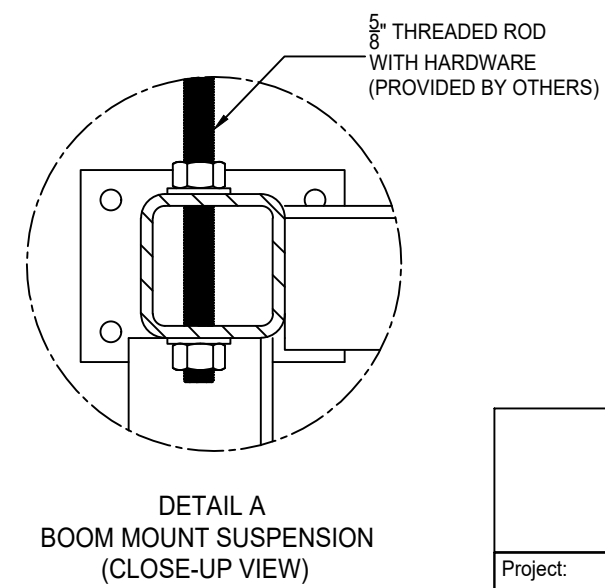
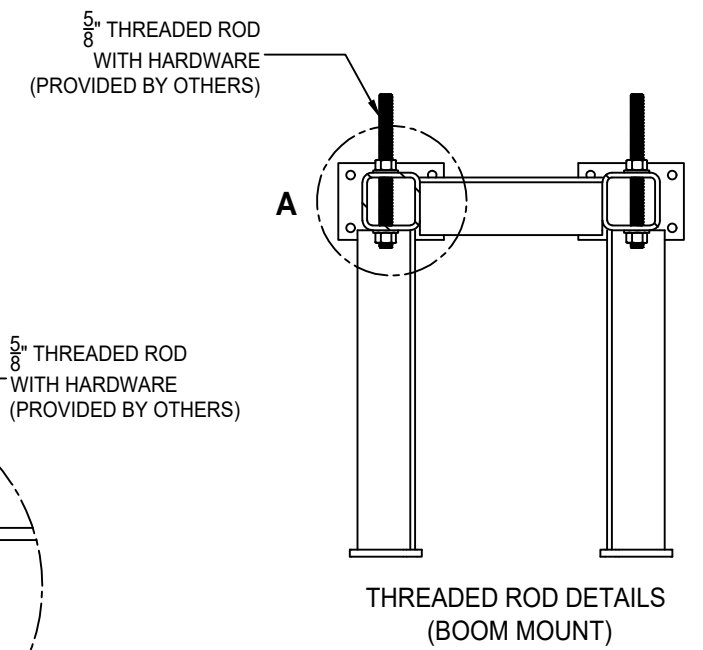
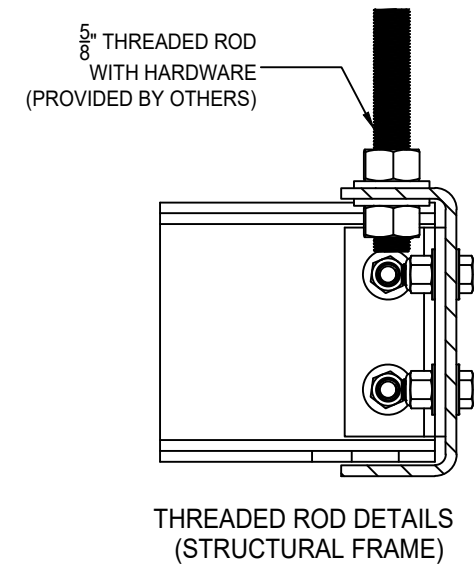
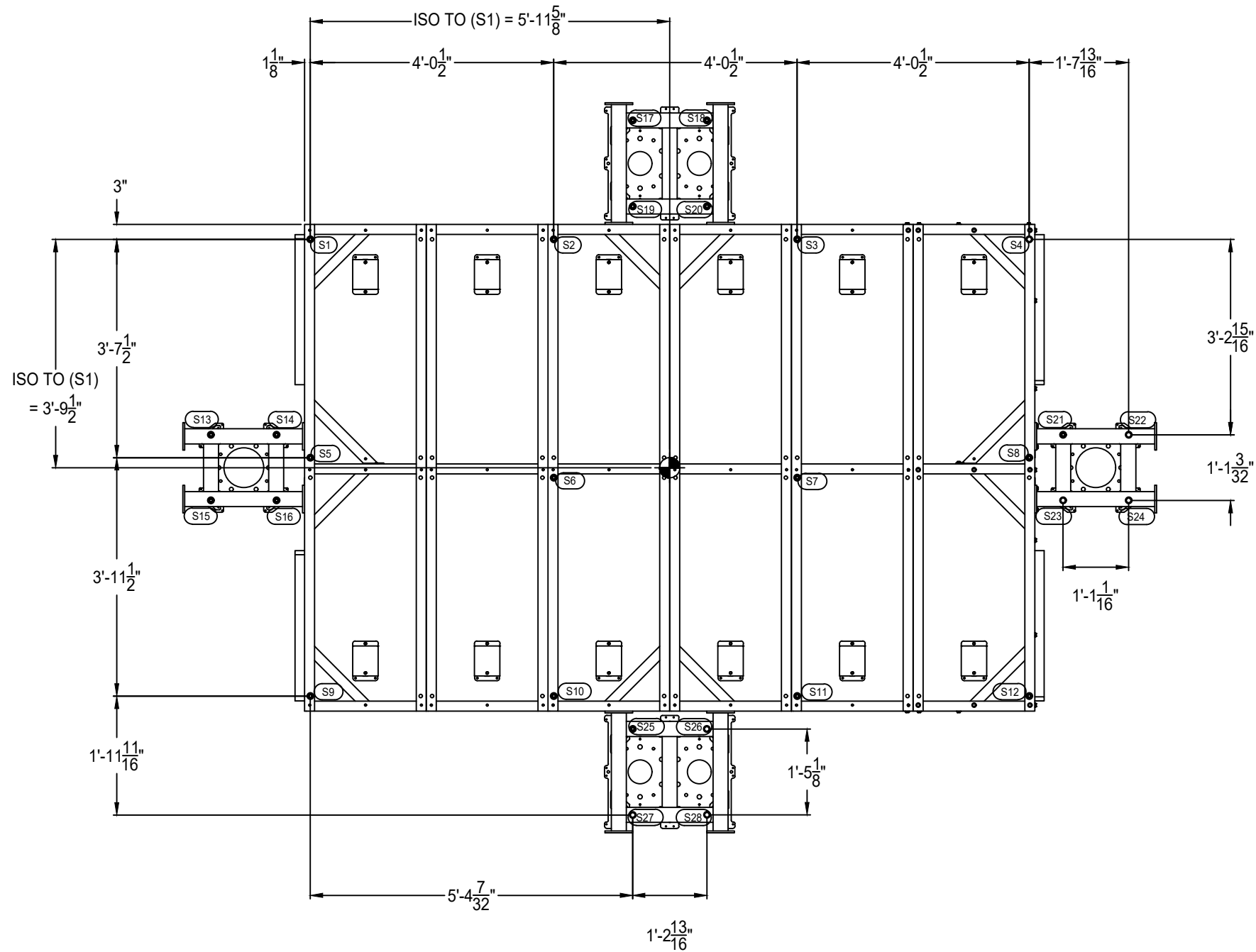

**PRICE** | **CRITICAL ENVIRONMENTS**

Project:		
276328	Revision: 0	01-12-2024

# ULTRASUITE® + STRUCTURE

## OPERATING ROOM DIFFUSER SYSTEM WITH INTEGRATED LED LIGHTING AND ALUMINUM STRUCTURAL SUPPORT STRUCTURAL DETAILS - ALUMINUM FRAMING - TRADITIONAL OR

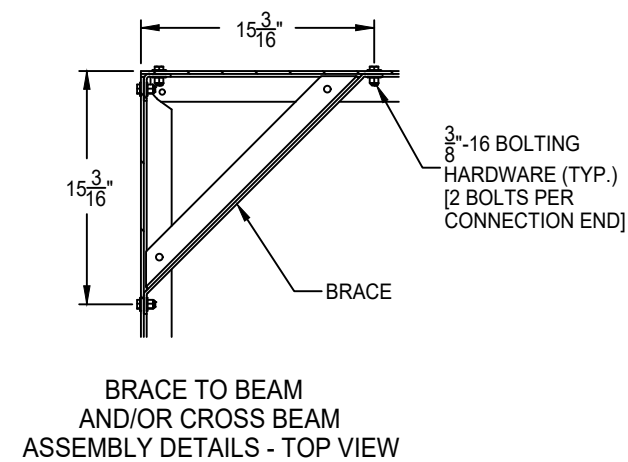
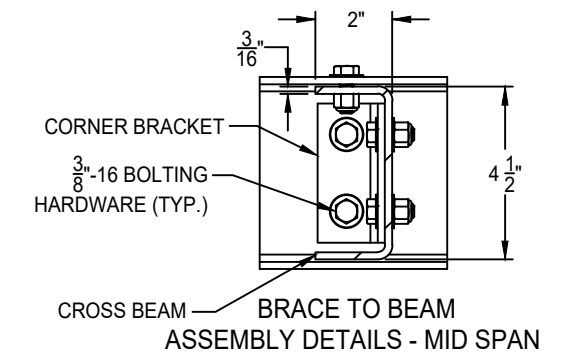
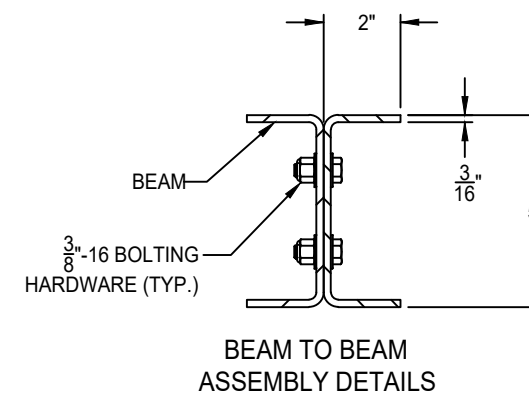
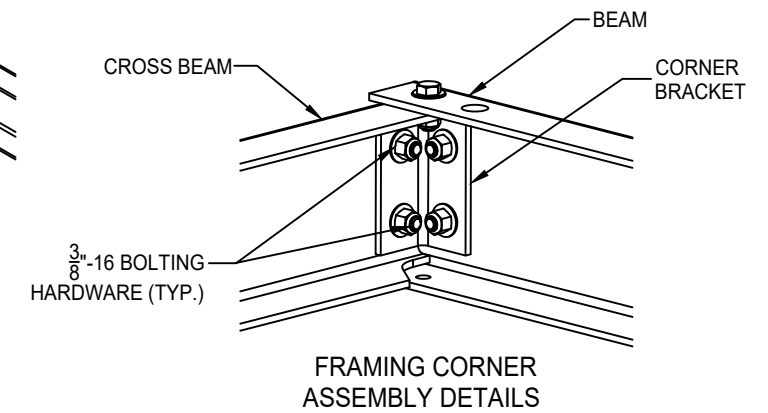
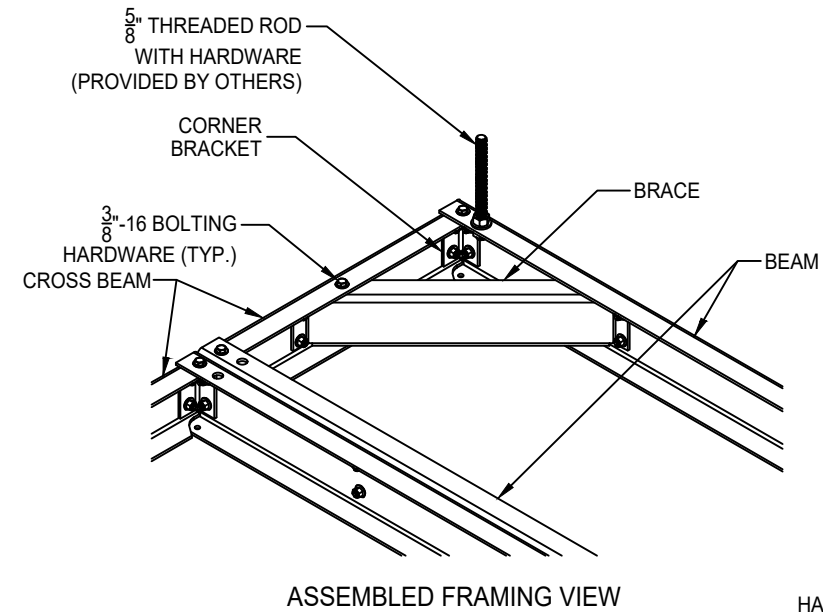
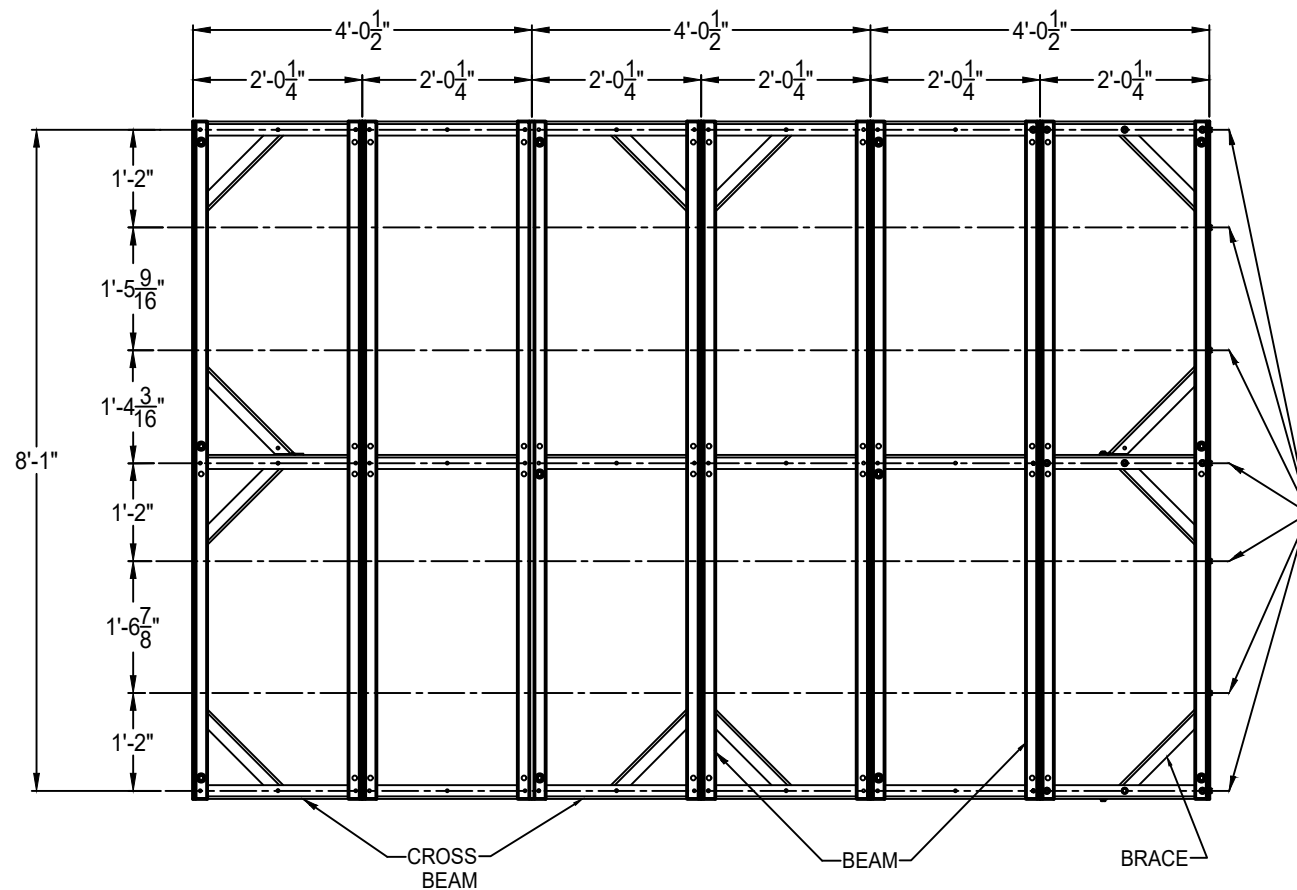

MEMBER NAME	SHAPE	PROFILE	MATERIAL
BEAM	C5" X 2" X 3/16"		ALUMINUM 5052H32
CROSS BEAM	C4-1/2" X 2" X 3/16"		
BRACE	C4" X 2" X 3/16"		
CORNER BRACKET	L1 3/4" X 1 3/4" X 3/16"		

**PRICE** | **CRITICAL ENVIRONMENTS**

Project: \_\_\_\_\_

276328	Revision: 0	01-12-2024
--------	-------------	------------





# ULTRASUITE® + STRUCTURE

## OPERATING ROOM DIFFUSER SYSTEM WITH INTEGRATED LED LIGHTING AND ALUMINUM STRUCTURAL SUPPORT STRUCTURAL DETAILS - SINGLE BOOM MOUNT DETAILS

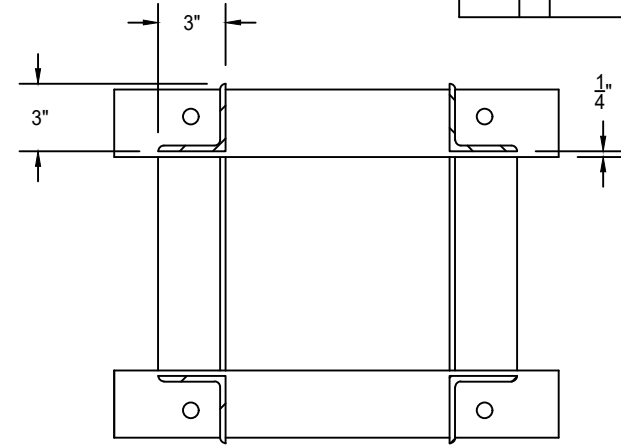
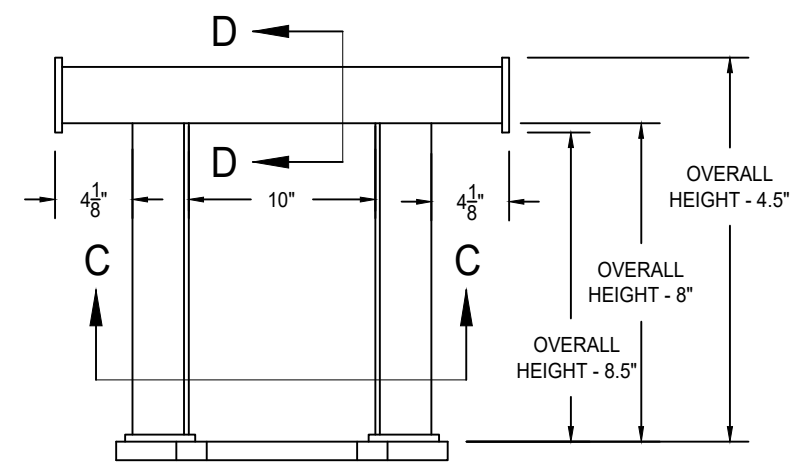
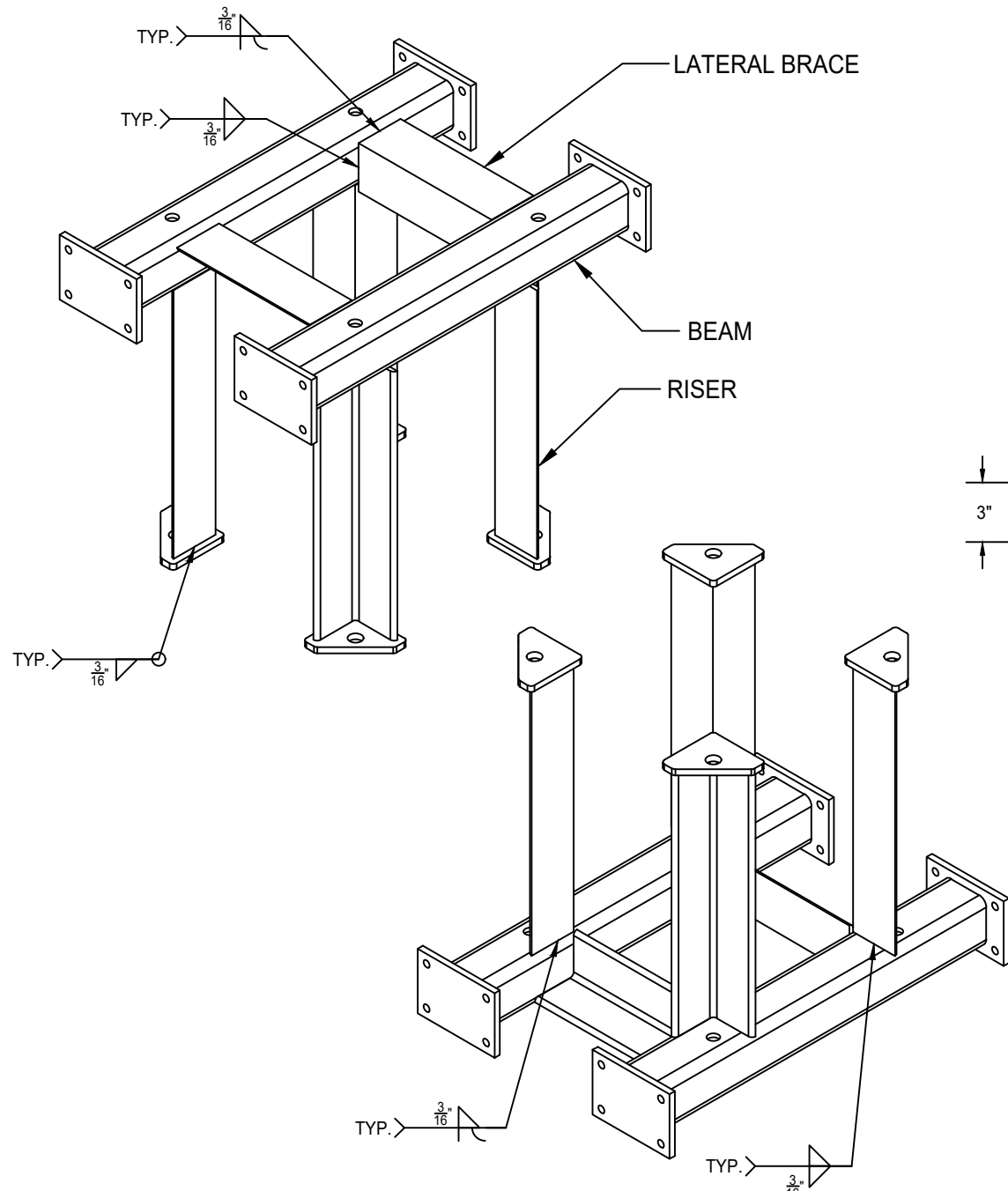

SECTION C-C

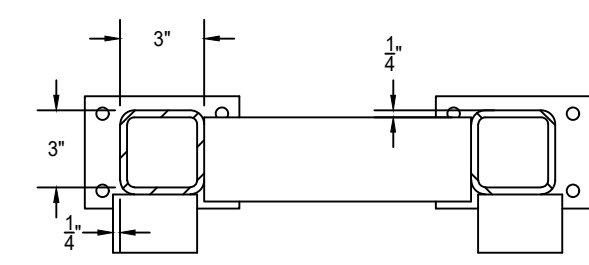

SECTION D-D

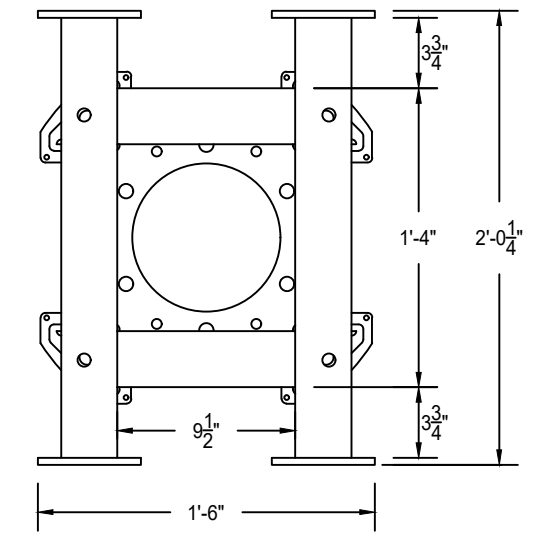
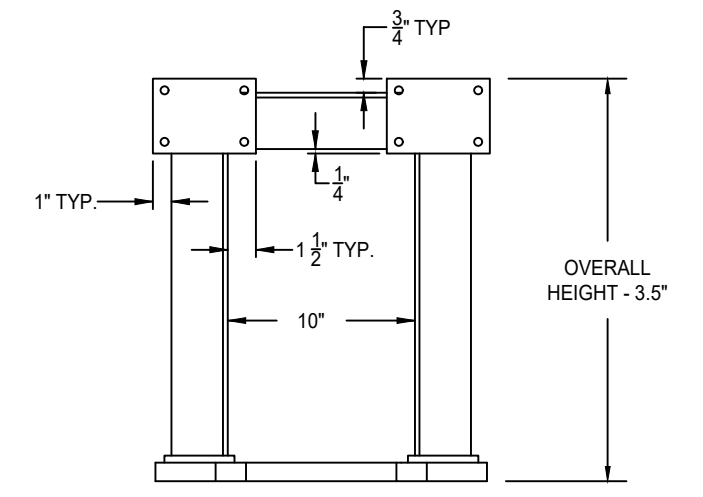

MEMBER NAME	SHAPE	PROFILE	MATERIAL
BEAM	HSS3" X 3" X 1/4"		ASTM A500 GR. B OR C
LATERAL BRACE AND RISER	L3" X 3" X 1/4"		A36 OR EQUIVALENT

**PRICE** | **CRITICAL ENVIRONMENTS**

Project: \_\_\_\_\_

276328	Revision: 0	01-12-2024
--------	-------------	------------

# ULTRASUITE® + STRUCTURE

## OPERATING ROOM DIFFUSER SYSTEM WITH INTEGRATED LED LIGHTING AND ALUMINUM STRUCTURAL SUPPORT STRUCTURAL DETAILS - TANDEM BOOM MOUNT DETAILS

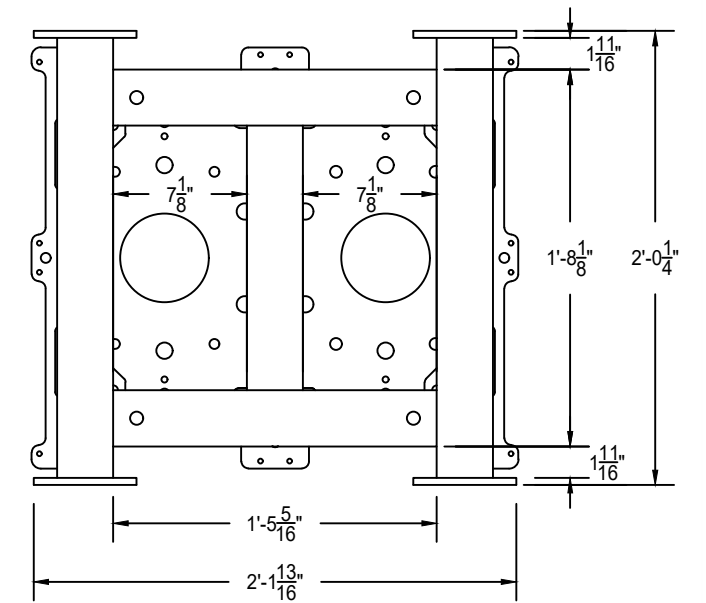
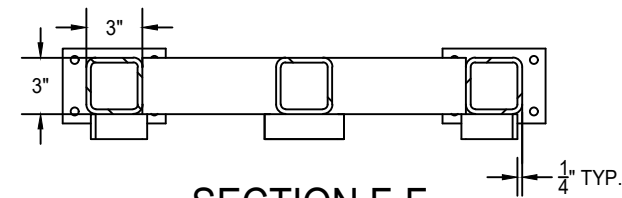
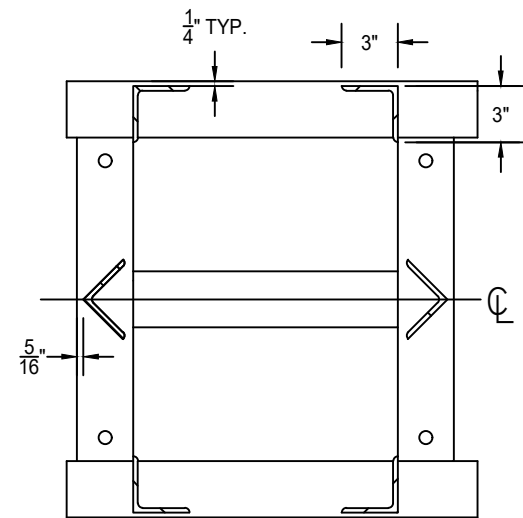
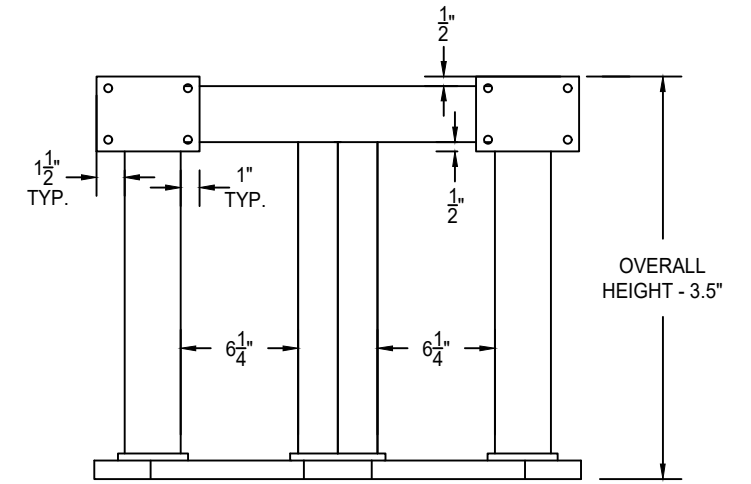
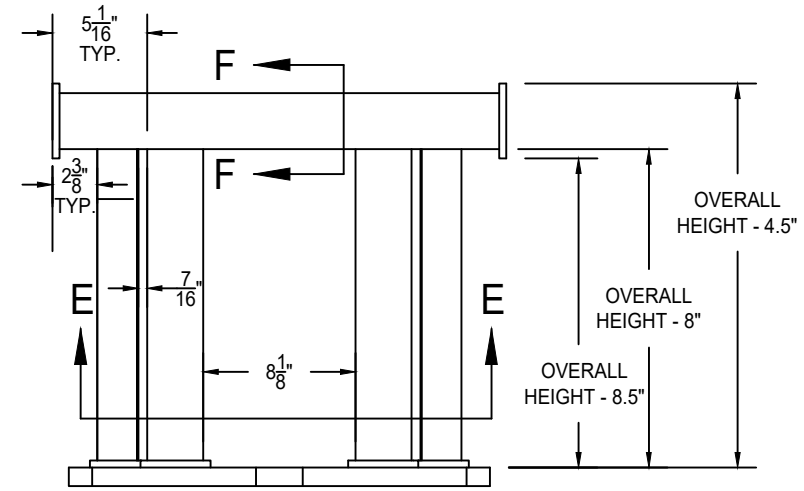
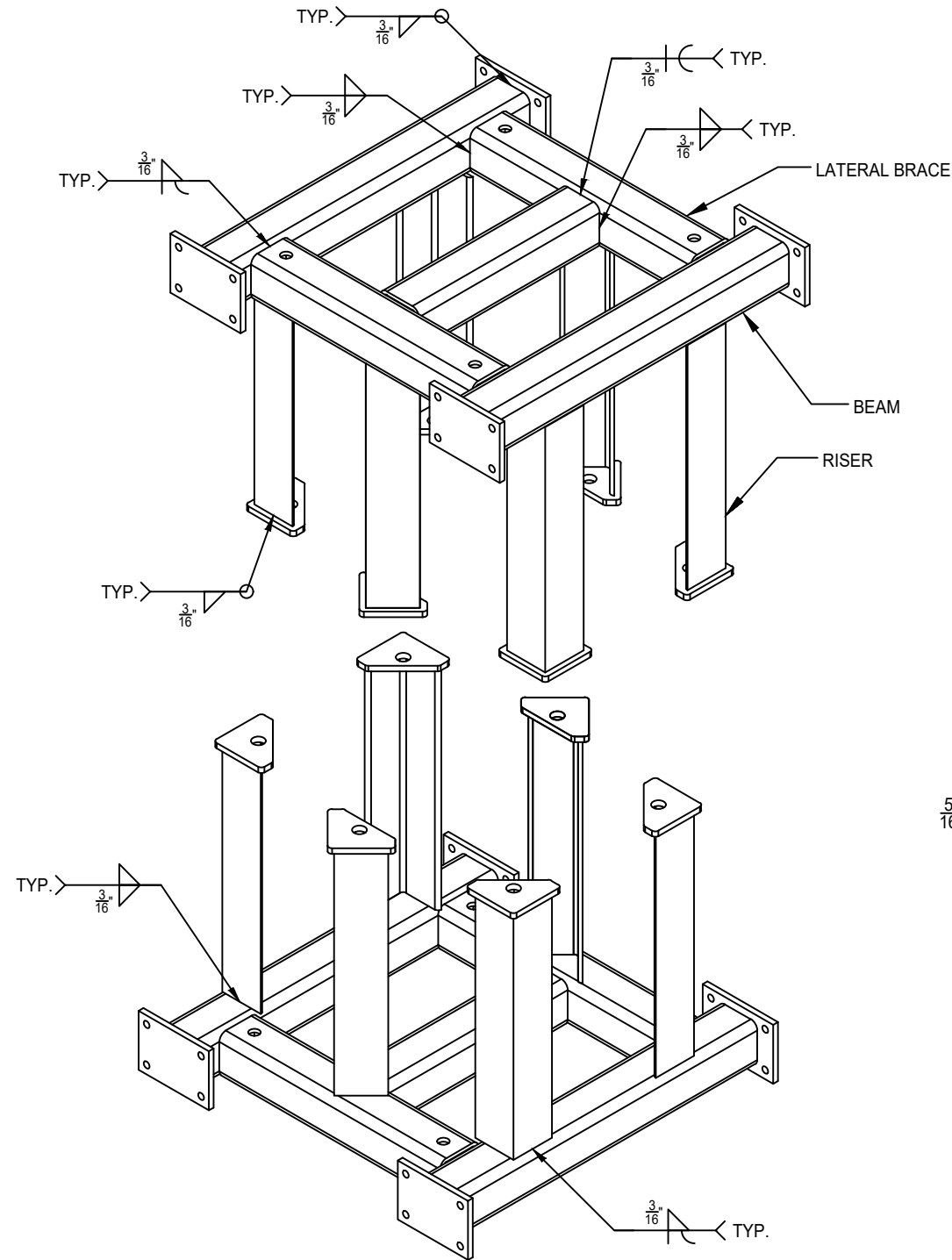

SECTION E-E

SECTION F-F

MEMBER NAME	SHAPE	PROFILE	MATERIAL
BEAM AND LATERAL BRACE	HSS3" X 3" X 1/4"		ASTM A500 GR. B OR C
RISER	L3" X 3" X 1/4"		A36 OR EQUIVALENT



Project:

276328

Revision: 0

01-12-2024

# ULTRASUITE® + STRUCTURE

## OPERATING ROOM DIFFUSER SYSTEM WITH INTEGRATED LED LIGHTING AND ALUMINUM STRUCTURAL SUPPORT HGWC SHIP SECTION BREAKDOWN & HANGING DETAILS - TRADITIONAL OR

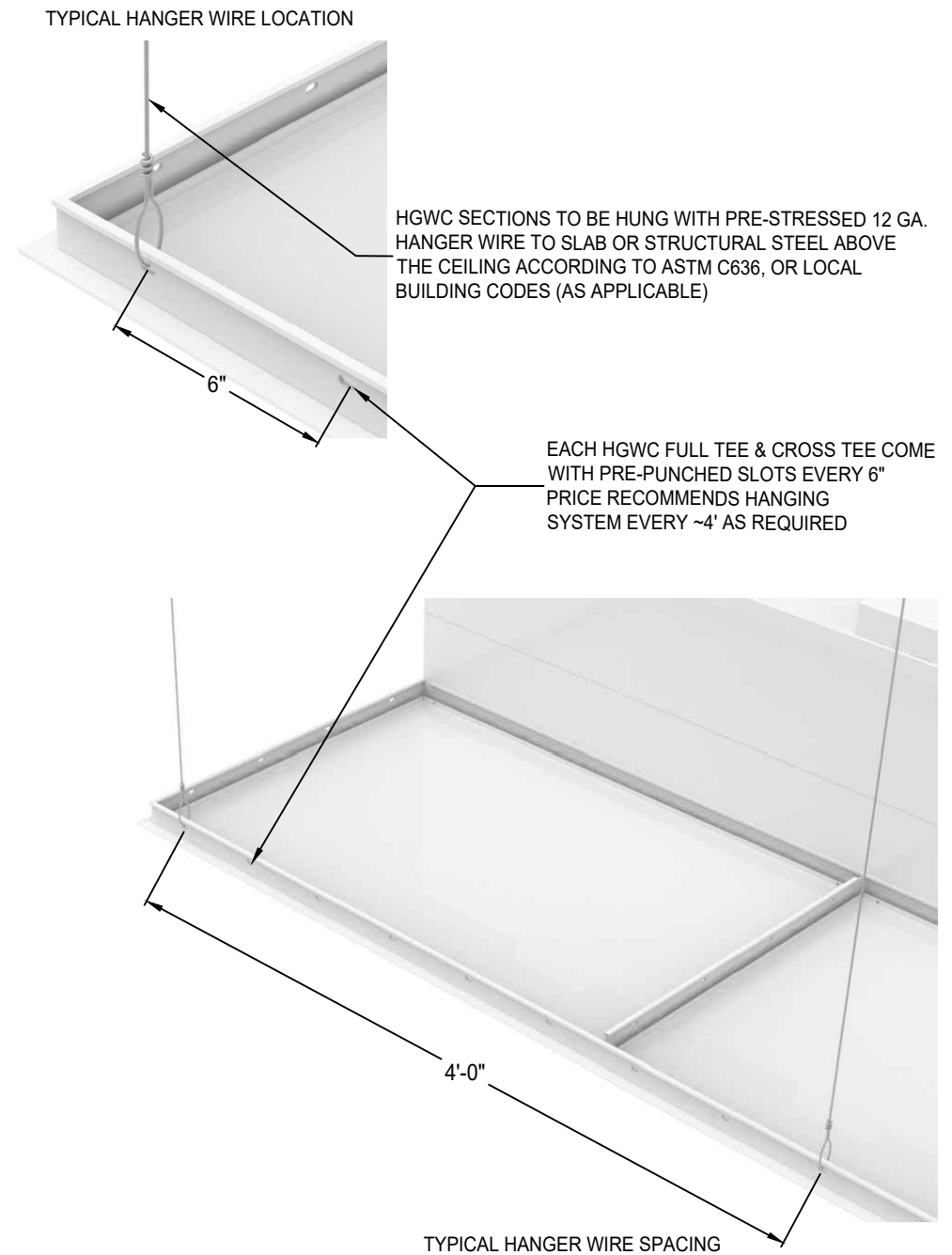
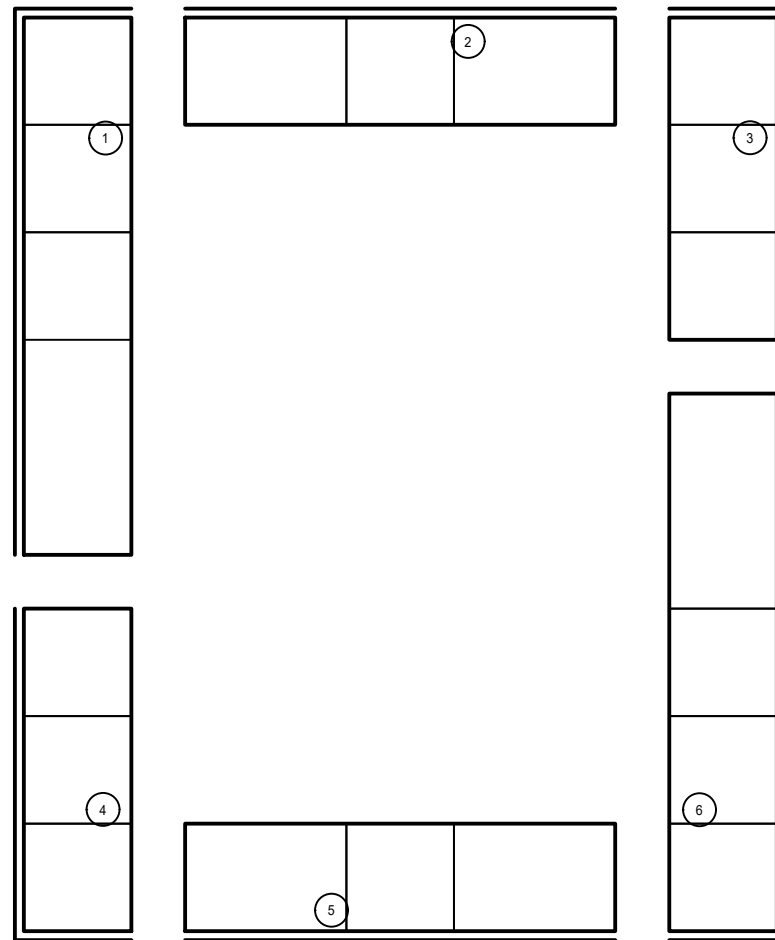
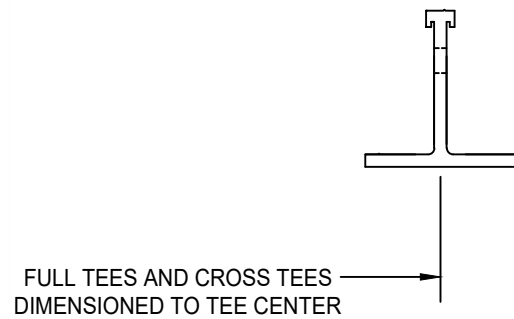
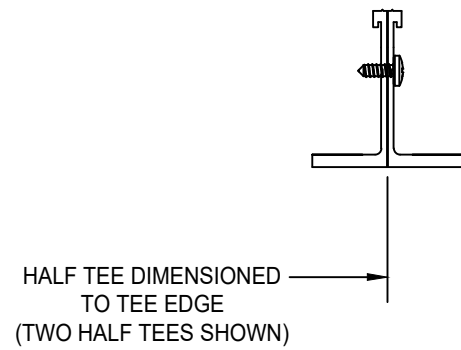
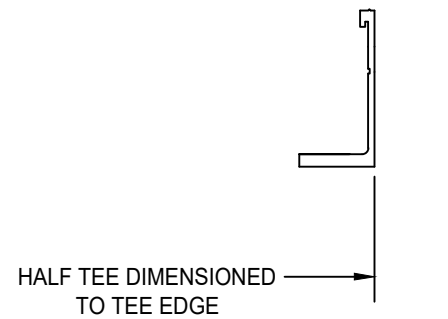

- THE HGWC GRID IS SUPPLIED IN MULTIPLE FACTORY ASSEMBLED SECTIONS NO LARGER THAN 10'x4'
- THE CEILING IS FACTORY PRE-MANUFACTURED TO SIZES AND TOLERANCE  $\pm \frac{1}{16}$ "

**PRICE** | **CRITICAL ENVIRONMENTS**

Project:

276328

Revision: 0

01-12-2024

# ULTRASUITE® + STRUCTURE

## OPERATING ROOM DIFFUSER SYSTEM WITH INTEGRATED LED LIGHTING AND ALUMINUM STRUCTURAL SUPPORT

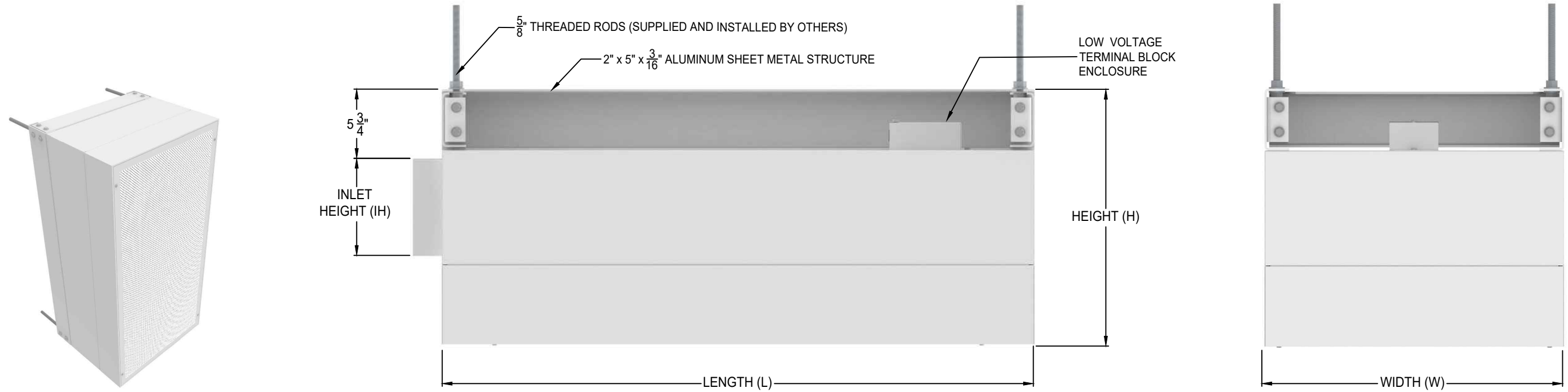

### STANDARD CONSTRUCTION

- 14 GA (.064" THICK) ALUMINUM PLENUM
- EXTRUDED ALUMINUM OUTER FRAME AND DIFFUSER FACE FRAME
- 5 GA (.188" THICK) SHEET METAL ALUMINUM STRUCTURE
- ROOM-SIDE ADJUSTABLE APERTURE PLATE DAMPER
- TWO STAINLESS STEEL RETAINER CABLES PER DIFFUSER FACE
- DIFFUSER FACE SECURED WITH 1/4 TURN FASTENERS

### LED LIGHTING SPECIFICATIONS

- LED LIGHTING INTEGRATED INTO EACH DIFFUSER MODULE
- IP67 RATED LED STRIP WITH QUICK CONNECTORS
- COLOR RENDERING INDEX (CRI) 95
- L80>60,000 HRS
- FOR IES PHOTOMETRIC FILES VISIT:  
[www.priceindustries.com/criticalenvironments/products/ultrasuite](http://www.priceindustries.com/criticalenvironments/products/ultrasuite)

### FINISH

- B12 WHITE
- OPTIONAL AMB12 ANTI-MICROBIAL WHITE

### LED COLOR TEMPERATURE

- 5000K (W935)
- OPTIONAL 4000K (W930)

### LISTINGS

- **UL 1598/CSA C22.2 #250.0** - AIR-HANDLING LUMINAIRES
- **UL 2043** - FIRE TEST FOR HEAT AND VISIBLE SMOKE RELEASE FOR DISCRETE PRODUCTS AND THEIR ACCESSORIES INSTALLED IN AIR-HANDLING SPACES
- **UL 2108/CSA 22.2#250.0** - LOW VOLTAGE LIGHTING SYSTEM
- **UL 8750/CSA-C22.2 #250.13** - LIGHT EMITTING DIODE (LED) EQUIPMENT FOR USE IN LIGHTING PRODUCTS
- **UL 1310/CSA C22.2 #223-M91** - CLASS 2 POWER UNITS
- **UL 94** - FLAMMABILITY OF PLASTIC MATERIALS FOR PARTS IN DEVICES AND APPLIANCES
- **IP 67** - RATED INGRESS PROTECTION AGAINST DUST AND LIQUIDS
- **MIL-STD-461** - ELECTROMAGNETIC COMPATIBILITY

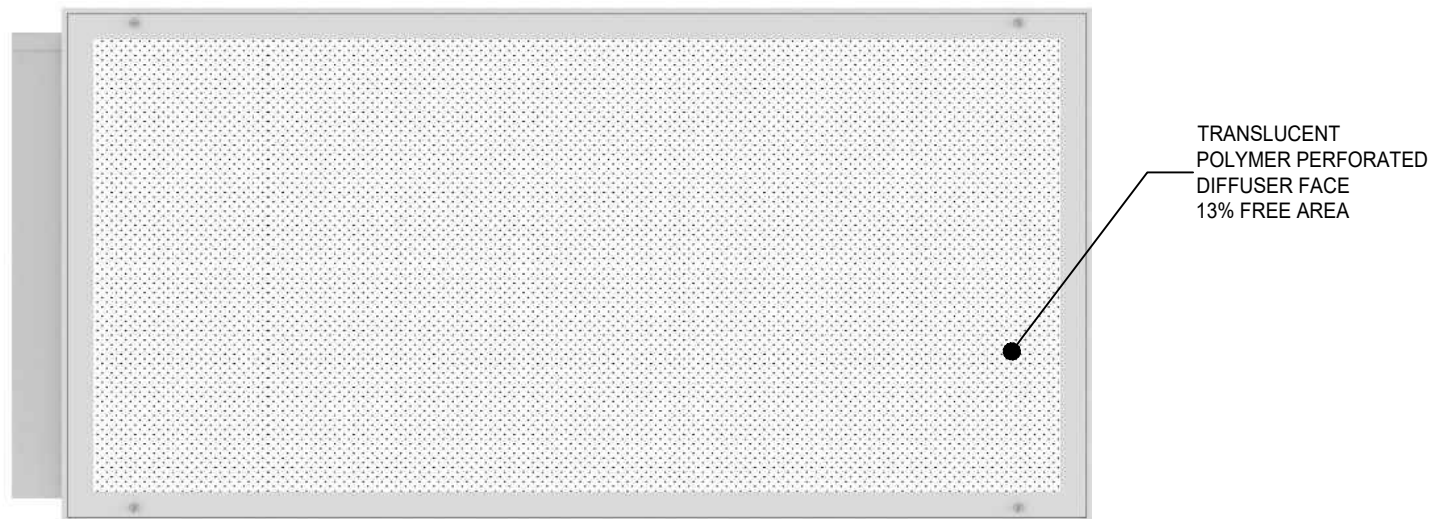

STANDARD MODULE SIZING CHART					
NOMINAL (W)	NOMINAL (L)	ACTUAL (W)	ACTUAL (L)	HEIGHT (H)	
				MIN	MAX
24.000	24.000	24.250	24.250	15	25
24.000	36.000	24.250	36.375	15	25
24.000	48.000	24.250	48.500	15	25

- STANDARD HEIGHT (H) = 20"
- MINIMUM HEIGHT WITH HEPA FILTER = 17"
- MINIMUM WIDTH WITH HEPA FILTER = 13"
- MAX INLET HEIGHT (IH) = HEIGHT (H) - 12"
- MAX INLET HEIGHT (IH) WITH HEPA = HEIGHT (H) - 13"

PRICE CEILING SYSTEM WEIGHTS		
PRICE SUPPLIED COMPONENTS	TOTAL SQUARE FEET =308 SQ.FT.	1713 lbs.
STRUCTURE	116 SQ.FT.	921 lbs.
USA	96 SQ.FT.	672 lbs.
HGWC+PANELS	96 SQ.FT.	120 lbs.

**price** | **CRITICAL ENVIRONMENTS**

Project:

276328

Revision: 0

01-12-2024



# ULTRASUITE® + STRUCTURE

## OPERATING ROOM DIFFUSER SYSTEM WITH INTEGRATED LED LIGHTING AND ALUMINUM STRUCTURAL SUPPORT

### FACE ACCESS APERTURE PLATE DAMPER DETAILS

○ OPTIONAL ROOMSIDE HEPA FILTRATION

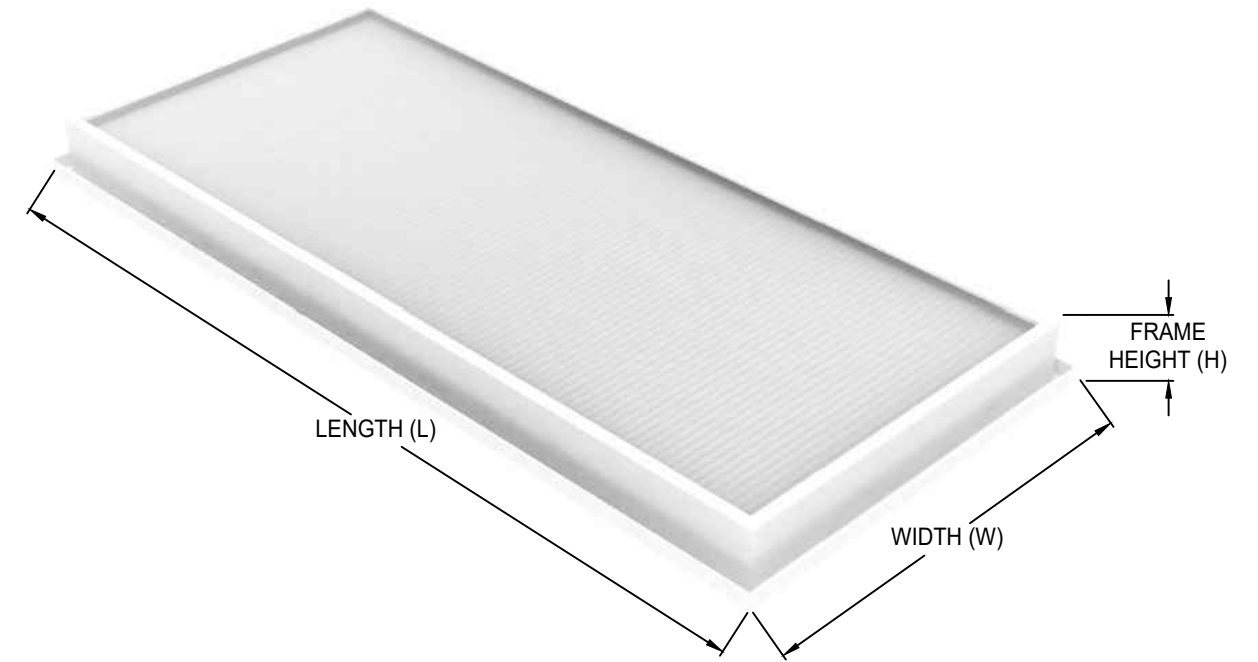
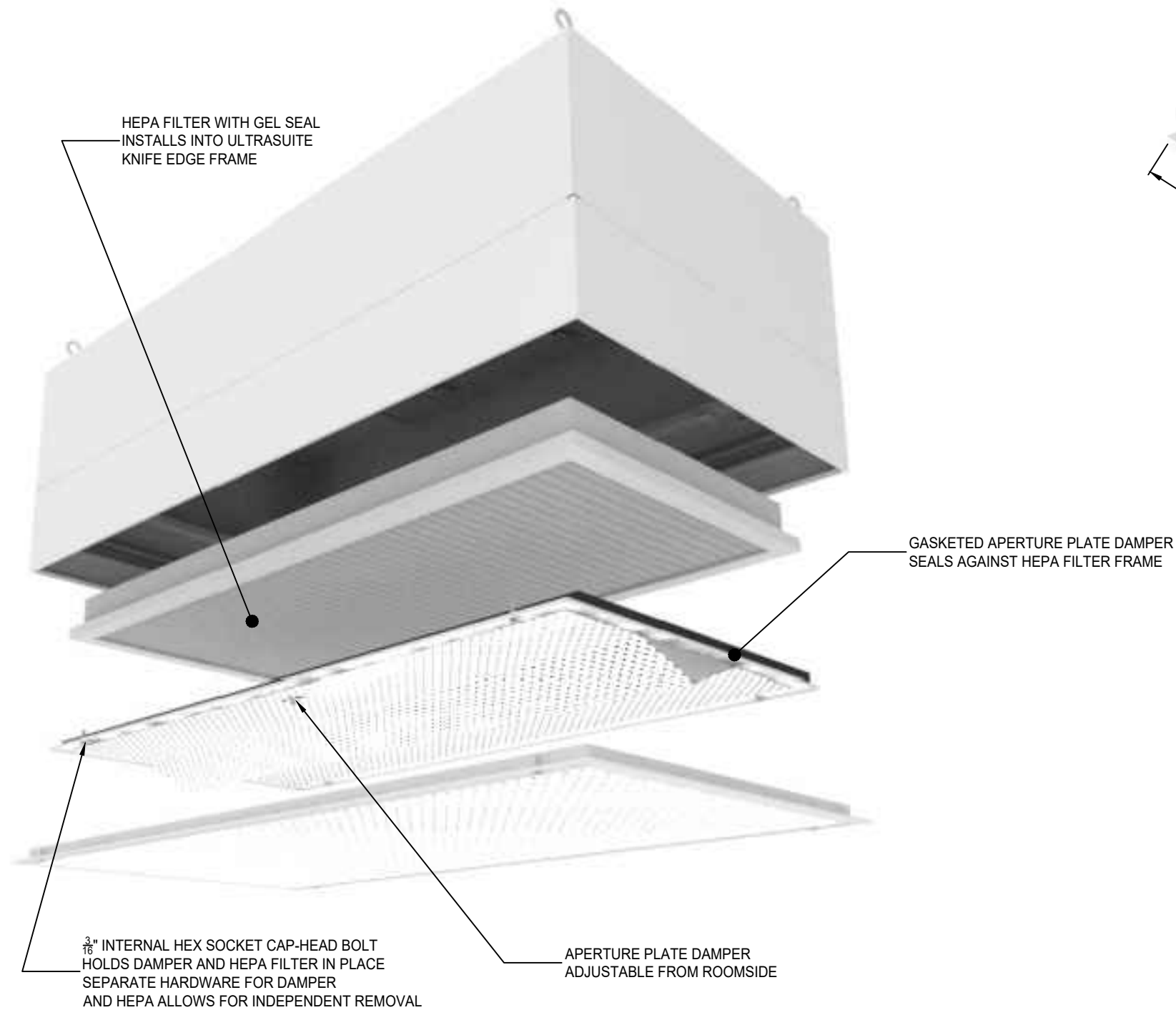

STANDARD FILTER SIZING CHART				
REPLACEMENT PART #	NOMINAL (W)	NOMINAL (L)	ACTUAL (W)	ACTUAL (L)
042299-029	24	24	19.88	19.88
042299-030	24	36	19.88	32.01
042299-032	24	48	19.88	44.13

**NOTES:**

- FILTER PLEATS RUN PARALLEL TO THE WIDTH (W) DIMENSION
- DIMENSIONS W & L TOLERANCES  $\pm \frac{1}{16}$ "
- FILTERS COME WITH GEL SEAL FILLED CHANNEL
- FILTERS MUST BE ORDERED SEPARATELY UNDER THE FTR-1-X LINESTRING

**FRAME DETAILS:**

- MATERIAL: ANODIZED EXTRUDED ALUMINUM
- THICKNESS:  $\frac{1}{16}$ " (MINIMUM)
- FILTERS ARE UL 900 CLASS 1 CERTIFIED
- EFFICIENCY AND LEAK SCAN TESTED
- HEPA EFFICIENCY: 99.99% (.3 MICRON)
- MINIMUM MODULE WIDTH FOR ROOMSIDE HEPA FILTRATION IS 12"



Project:

276328

Revision: 0

01-12-2024

VISIT PRICE INDUSTRIES WEBSITE FOR FILTER QUICK START GUIDE

<https://www.priceindustries.com/content/uploads/assets/literature/manuals/section%20e/ftr-room-side-replaceable-filter-rsr-quick-start-guide.pdf>

NOTE:

UL 1598 DOES NOT HAVE PROVISIONS FOR HEPA FILTERS MOUNTED WITHIN FIXTURE. USA COMPLIES WITH UL 1598 WITH HEPA FILTERS ORDERED SEPERATELY ON FTR-1-X LINESTRING.

# ULTRASUITE® + STRUCTURE

## OPERATING ROOM DIFFUSER SYSTEM WITH INTEGRATED LED LIGHTING AND ALUMINUM STRUCTURAL SUPPORT

### FACE ACCESS APERTURE PLATE DAMPER DETAILS

- OPTIONAL ROOMSIDE HEPA FILTRATION

#### FILTER HOLD DOWN TAB DETAIL

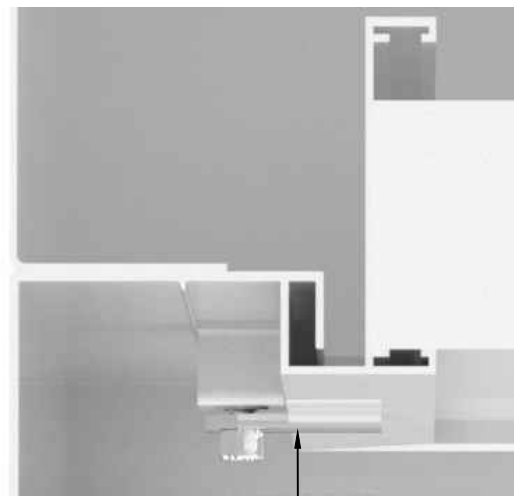

OPTIONAL  
FILTER HOLD  
DOWN TAB

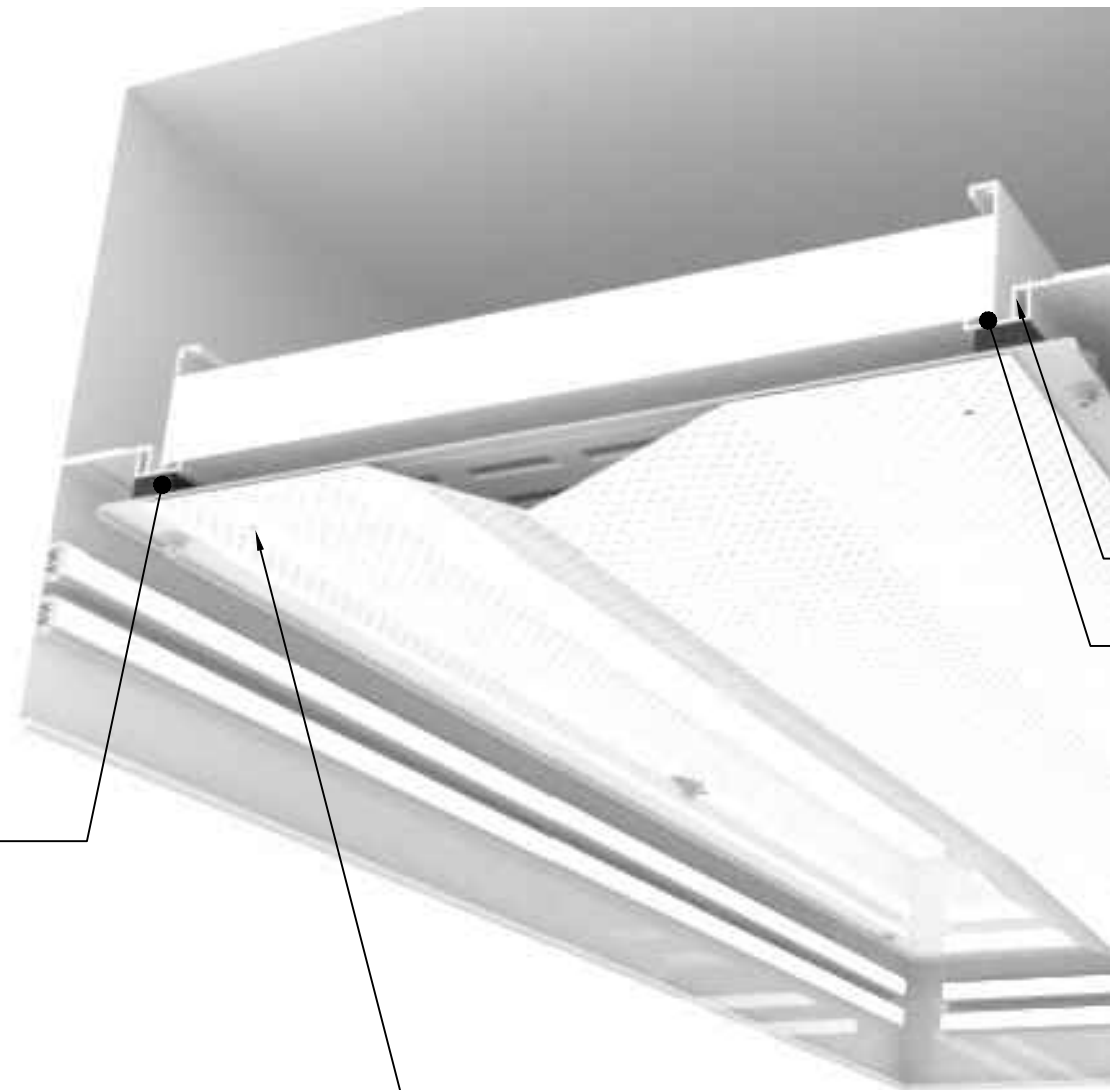

APERTURE PLATE  
DAMPER WITH UL2043  
RATED GASKET  
SEALS AGAINST  
THE KNIFE EDGE

DAMPER SECURED  
IN PLACE WITH SCREWS  
INSTALL BY USING  $\frac{3}{16}$ " ALLEN KEY

KNIFE EDGE

HEPA FILTER  
GEL SEAL

#### STATIC PRESSURE PORT DETAIL

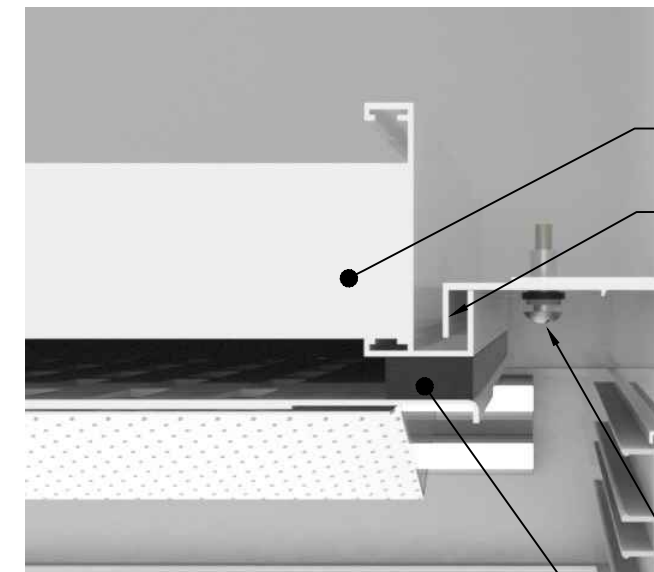

OPTIONAL  
HEPA FILTER

KNIFE EDGE

STATIC  
PRESSURE  
PORT

APERTURE PLATE  
DAMPER WITH UL2043  
RATED GASKET  
SEALS AGAINST  
THE HEPA FRAME

**PRICE** | **CRITICAL ENVIRONMENTS**

Project:

276328

Revision: 0

01-12-2024

# ULTRASUITE® + STRUCTURE

## OPERATING ROOM DIFFUSER SYSTEM WITH INTEGRATED LED LIGHTING AND ALUMINUM STRUCTURAL SUPPORT URDC ULTRA REMOTE DRIVER CABINETS - STANDARD OFFERINGS

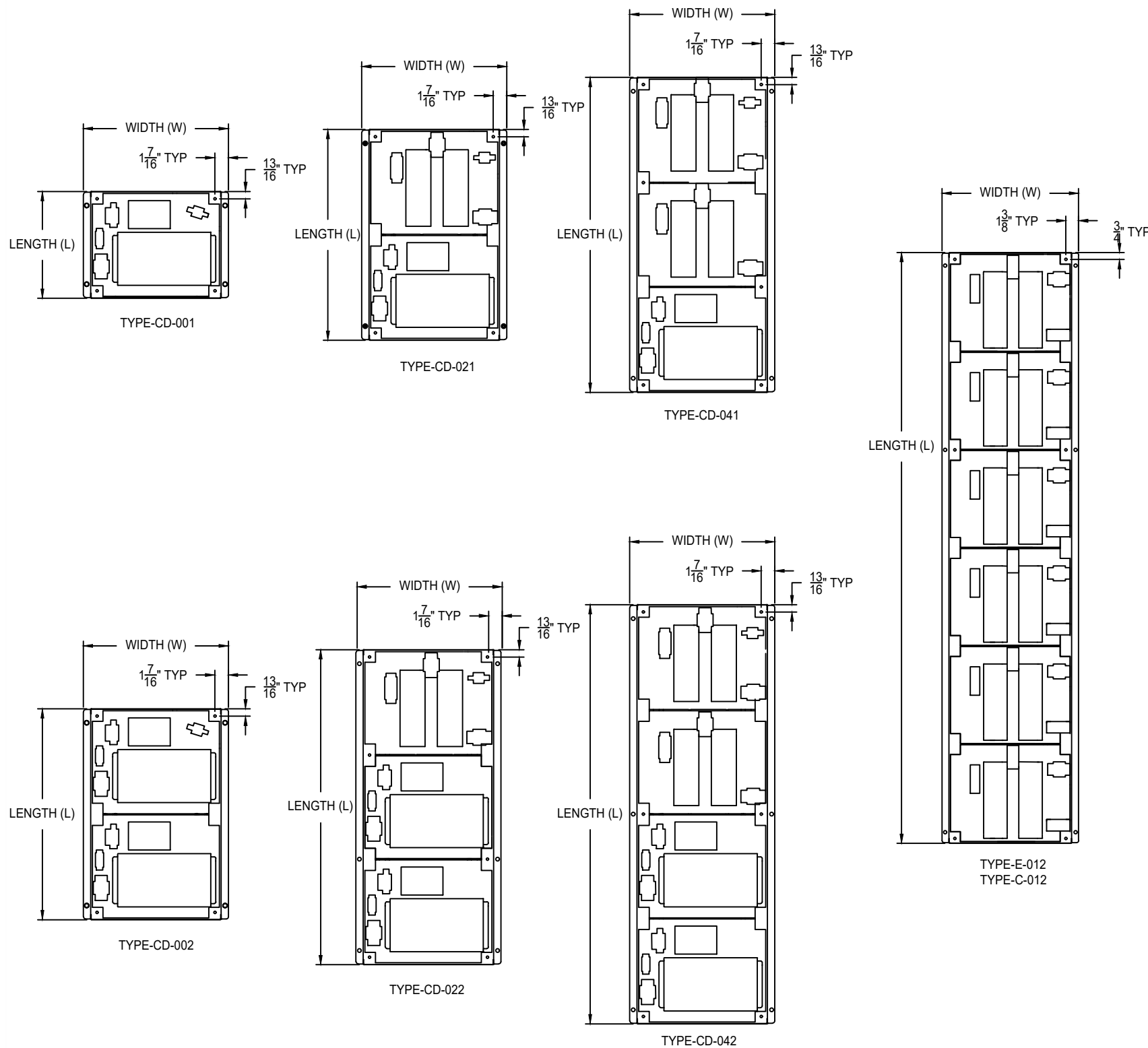

- ALL DRIVER CABINETS ARE ORDERED ON URDC-1-X LINESTRING.
- REMOTE DRIVER CABINETS REQUIRE SINGLE POINT HIGH VOLTAGE (120-277v~) CONNECTION (277V~ RECOMMENDED).
- ALL DIMMING SWITCHES ARE ORDERED ON UCA-1-X LINESTRING.
- 0-10V DIMMING SWITCH SHIPPED LOOSE. THE TOTAL LENGTH FOR 0-10V CONTROL SIGNAL WIRING FOR THIS CONTROL SHOULD NOT EXCEED 500'. DO NOT USE WIRE SMALLER THAN 20 AWG.
- 8A AND 16A 0-10V DIMMING SWITCHES AVAILABLE. DIMMING ZONES AND CONTROL ARE COMPLETELY CUSTOMIZABLE.
- 0-10V DIMMING SIGNAL FROM SWITCH CAN CONTROL UP TO 100 DRIVERS.
- LED DRIVER TYPE E OFFERS CONTINUOUS, FLICKER-FREE DIMMING FROM 100% TO 1% WITH 0-10 VOLTAGE DIMMER SHIPPED LOOSE OR DIMMING SIGNAL PROVIDED BY OTHERS.
- LED DRIVER TYPE C AND CD OFFERS CONTINUOUS, FLICKER-FREE DIMMING FROM 100% TO 10% WITH 0-10 VOLTAGE DIMMER SHIPPED LOOSE. OPTIONAL SOLID STATE RELAY WITH 4-32VDC RELAY SHUT OFF SIGNAL AND 0-10VDC DIMMING SIGNAL PROVIDED BY OTHERS
- 30A DISCONNECT SWITCH AVAILABLE TO PROVIDE FULL SYSTEM SHUTOFF WHEN UTILIZING 0-10V SIGNAL
- LED DRIVERS SHIP FACTORY WIRED AND INSTALLED IN REMOTE DRIVER CABINETS.
- URDC DRIVER CABINETS CAN BE WALL MOUNTED, TYPICALLY IN AN ADJACENT EQUIPMENT ROOM, OR INSTALLED ABOVE THE CEILING. DRIVER CABINETS CANNOT BE RECESSED BETWEEN WALL STUDS AS THEY REQUIRE VENTILATION.
- ULTRASUITE MODULES COME WITH FACTORY WIRED AND INSTALLED TOP MOUNTED LOW VOLTAGE TERMINAL BLOCK ENCLOSURE
- INCOMING HIGH VOLTAGE POWER AND LOW VOLTAGE CONNECTION BETWEEN ULTRASUITE MODULES AND REMOTE DRIVER CABINET ARE THE RESPONSIBILITY OF THE INSTALLER.
- MAX DISTANCE BETWEEN ULTRASUITE MODULE AND REMOTE DRIVER CABINET IS DEPENDANT ON WIRE GAUGE TO MINIMIZE VOLTAGE DROP. SEE TABLE BELOW.
- SEE ULTRASUITE INSTALLATION MANUAL AVAILABLE AT <https://www.priceindustries.com/criticalenvironments/products/ultrasuite> FOR RECOMMENDED REMOTE DRIVER CABINET AND ULTRASUITE SYSTEM INSTALLATION.

DRIVER CABINET	# OF MODULES	# OF DRIVERS	L	W	H	WEIGHT	AC CURRENT - TYPE E (120VAC / 277VAC)	AC CURRENT - TYPE C (120VAC / 277VAC)
TYPE E/C-001	1	1	0'-11 1/2"	1' - 3 1/2"	5"	7 lbs.	0.95A / 0.4A	1.2A / 0.50A
TYPE E/C-002		2	0'-11 1/2"	1' - 3 1/2"	5"	15 lbs.	1.9A / 0.8A	2.4A / 1.7A
TYPE E/C-003	2	3	1' - 10 9/16"	1' - 3 1/2"	5"	22 lbs.	2.95A / 1.2A	3.6A / 2.9A
TYPE E/C-004		4	1' - 10 9/16"	1' - 3 1/2"	5"	30 lbs.	3.8A / 1.6A	4.8A / 4.1A
TYPE E/C-005	3	5	2' - 9 11/16"	1' - 3 1/2"	5"	37 lbs.	4.75A / 2A	6.0A / 5.3A
TYPE E/C-006		6	2' - 9 11/16"	1' - 3 1/2"	5"	45 lbs.	5.7A / 2.4A	7.2A / 6.5A
TYPE E/C-007	4	7	3' - 8 13/16"	1' - 3 1/2"	5"	52 lbs.	6.65A / 2.8A	8.4A / 7.7A
TYPE E/C-008		8	3' - 8 13/16"	1' - 3 1/2"	5"	60 lbs.	7.6A / 3.2A	9.6A / 8.9A
TYPE E/C-009	5	9	4' - 7 15/16"	1' - 3 1/2"	5"	67 lbs.	8.55A / 3.6A	10.8A / 10.1A
TYPE E/C-010		10	4' - 7 15/16"	1' - 3 1/2"	5"	75 lbs.	9.5A / 4A	12.0A / 11.3A
TYPE E/C-011	6	11	5' - 7 1/16"	1' - 3 1/2"	5"	82 lbs.	10.45A / 4.4A	13.2A / 12.5A
TYPE E/C-012		12	5' - 7 1/16"	1' - 3 1/2"	5"	90 lbs.	11.4A / 4.8A	14.4A / 13.7A

DRIVER CABINET	# OF MODULES	# OF DRIVERS	L	W	H	WEIGHT	AC CURRENT - TYPE E (120VAC / 277VAC)
TYPE-CD-001	3	1	0'-11 1/2"	1' - 3 1/2"	5"	20 lbs.	7A / 2.9A
TYPE-CD-021	4	3	1' - 10 9/16"	1' - 3 1/2"	5"	35 lbs.	9.4A / 3.9A
TYPE-CD-041	5	5	2' - 9 11/16"	1' - 3 1/2"	5"	50 lbs.	11.8A / 4.9A
TYPE-CD-002	6	2	1' - 10 9/16"	1' - 3 1/2"	5"	40 lbs.	14.0A / 5.8A
TYPE-CD-022	7	4	2' - 9 11/16"	1' - 3 1/2"	5"	55 lbs.	- / 6.8A
TYPE-CD-042	8	6	3' - 8 13/16"	1' - 3 1/2"	5"	70 lbs.	- / 7.8A

- TYPE C & CD OFFERS 100 TO 10% DIMMING
- TYPE E OFFERS 100 TO 1% DIMMING
- TYPE CD OFFERS OVER 40% SPACE SAVING FOR CABINET INSTALLATION
- TYPE C ALLOWS FOR RECESSED TYPE IC INSTALLATION
- TYPE E & CD ALLOWS FOR SURFACE, WALL OR CEILING MOUNT INSTALLATION. PASSIVE VENTILATION OF CABINET IS REQUIRED THROUGH OUTER BOX LOUVERS

**PRICE** | **CRITICAL ENVIRONMENTS**

Project:

276328

Revision: 0

01-12-2024

# ULTRASUITE® + STRUCTURE

## OPERATING ROOM DIFFUSER SYSTEM WITH INTEGRATED LED LIGHTING AND ALUMINUM STRUCTURAL SUPPORT

### ○ URDC ULTRA REMOTE DRIVER CABINETS - WIRING FOR SINGLE DIMMING ZONE (100 TO 1% DIMMING)

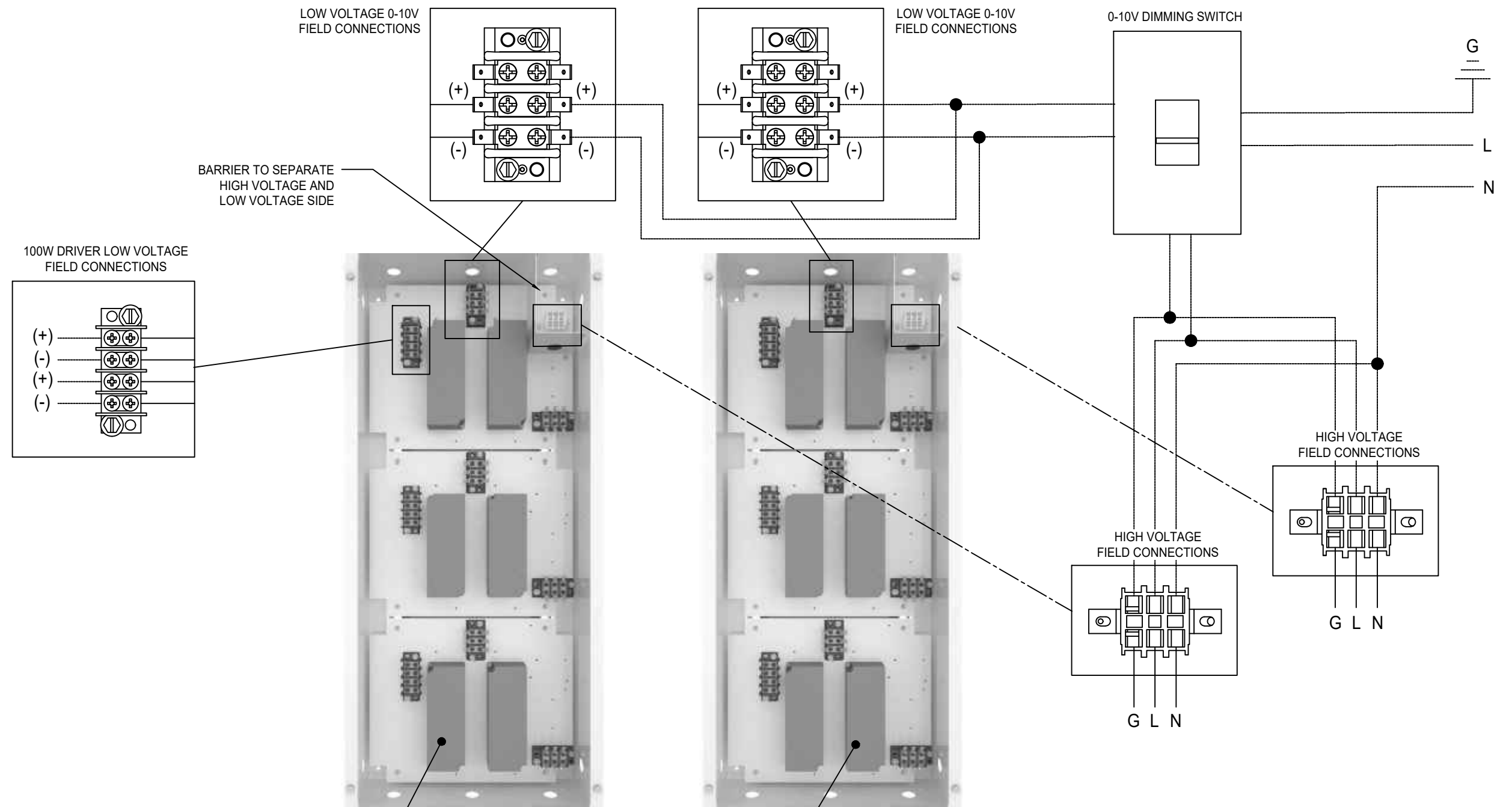

ALL INTERNAL REMOTE DRIVER CABINET WIRING IS DONE IN THE FACTORY

URDC-1-X REMOTE DRIVER CABINET TYPE E SHOWN

ALL INTERNAL REMOTE DRIVER CABINET WIRING IS DONE IN THE FACTORY

— PRE-WIRED FACTORY CONNECTION  
 - - - FIELD CONNECTION  
 G GROUND  
 N NEUTRAL  
 L LINE CONNECTION



Project:		
276328	Revision: 0	01-12-2024

• VISUAL WIRING DETAIL IS SHOWN FOR REFERENCE ONLY, REFERENCE INSTALLATION MANUAL FOR WIRING DIAGRAMS  
 • INSTALLATION WORK AND ELECTRICAL WIRING MUST BE COMPLETED BY A CERTIFIED ELECTRICIAN AND/OR QUALIFIED PERSON(S) IN ACCORDANCE WITH APPLICABLE ELECTRICAL CODES AND STANDARDS

# ULTRASUITE® + STRUCTURE

## OPERATING ROOM DIFFUSER SYSTEM WITH INTEGRATED LED LIGHTING AND ALUMINUM STRUCTURAL SUPPORT

### HGWC INTEGRATION DETAILS

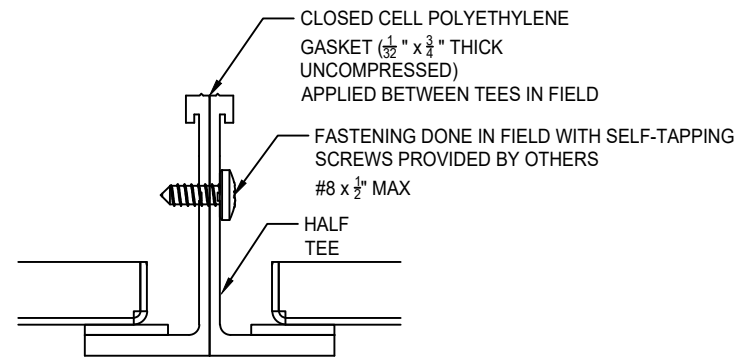

**A** HALF TEE FIELD JOINT

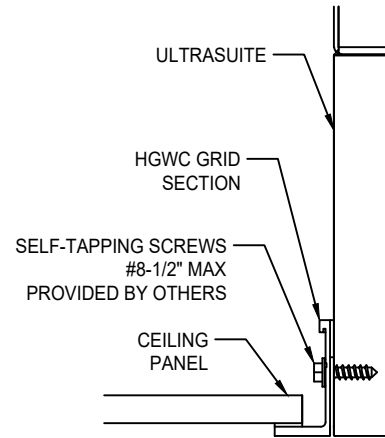

**C** HGWC GRID INTEGRATION

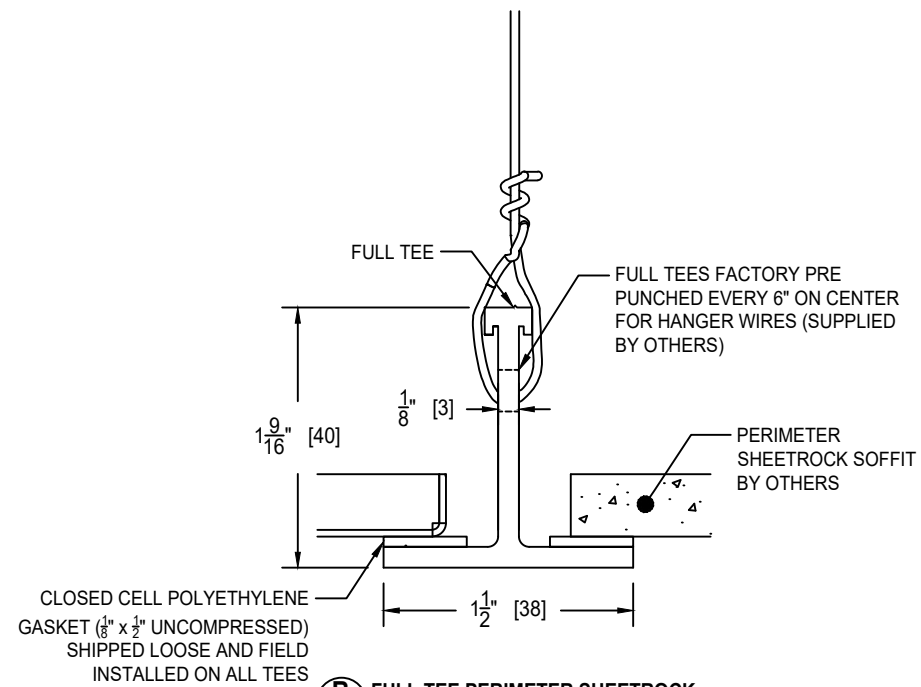

**B** FULL TEE PERIMETER SHEETROCK SOFFIT DETAIL

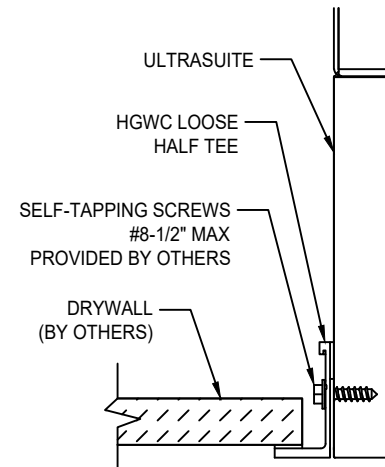

**D** PERIMETER HALF TEE INTEGRATION

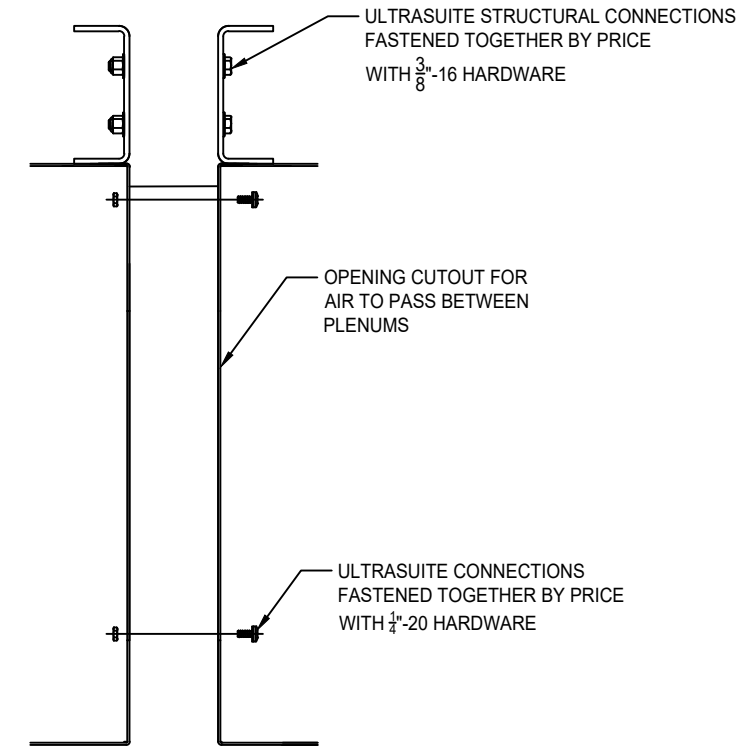

**E** BOLTED JOINT ASSEMBLY

**PRICE** | **CRITICAL ENVIRONMENTS**

Project:

276328

Revision: 0

01-12-2024



# ULTRASUITE<sup>®</sup> + STRUCTURE

## OPERATING ROOM DIFFUSER SYSTEM WITH INTEGRATED LED LIGHTING AND ALUMINUM STRUCTURAL SUPPORT

### SC - SOLID CORE

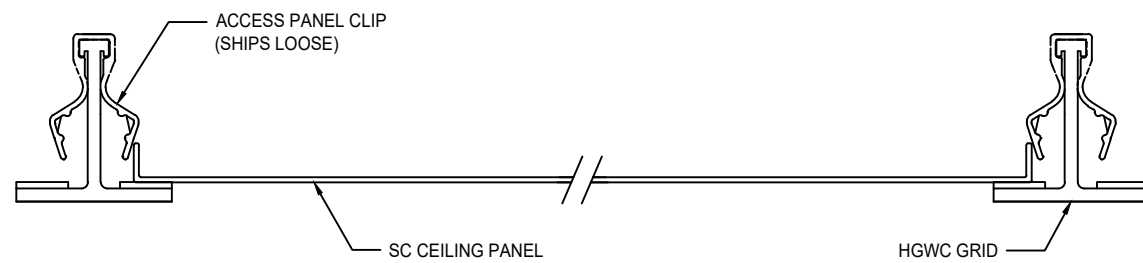
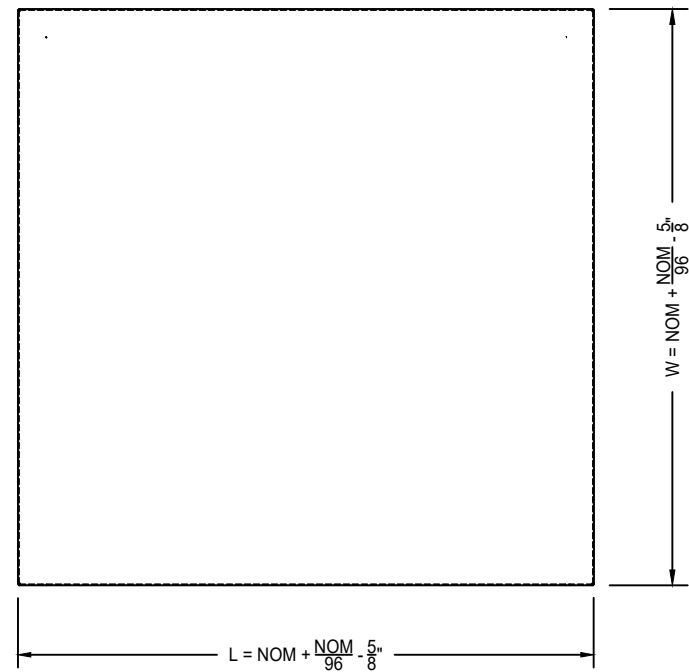

### SCF - SOLID CORE WITH FLUSH MOUNT FRAME

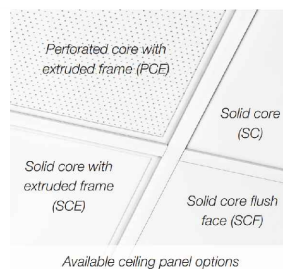
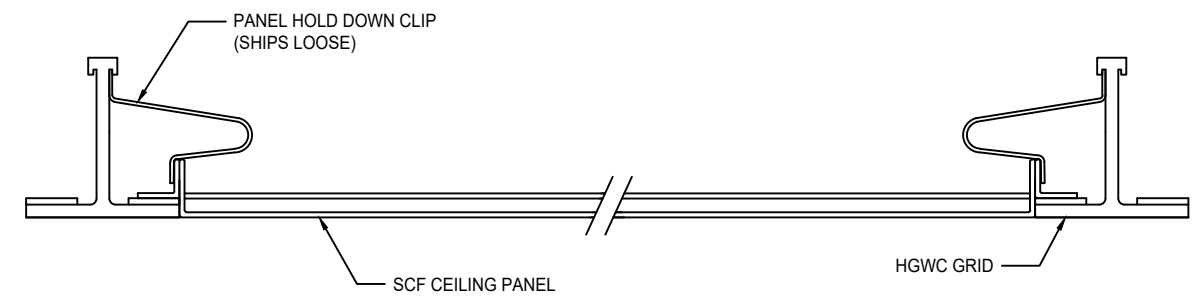
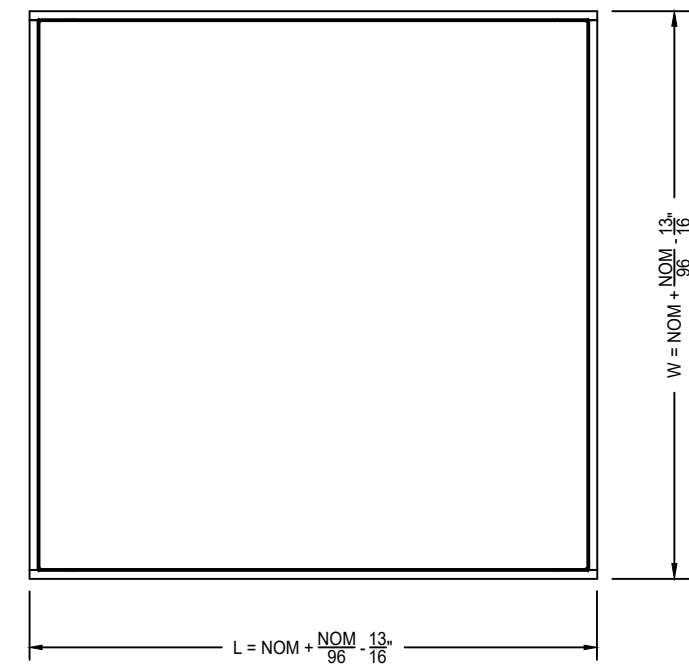

**PANEL MATERIAL / FINISH:**

- SC PANEL - .080" ALUMINUM / B12 STANDARD WHITE
- SCF PANEL - .040" ALUMINUM / B12 STANDARD WHITE

**CEILING TYPE:**

- HGWC - 1 1/2" HOSPITAL GRADE WELDED CEILING SYSTEM



Project:

276328

Revision: 0

01-12-2024

# ULTRASUITE® + STRUCTURE

## OPERATING ROOM DIFFUSER SYSTEM WITH INTEGRATED LED LIGHTING AND ALUMINUM STRUCTURAL SUPPORT

### SUPPORTING CONTENT

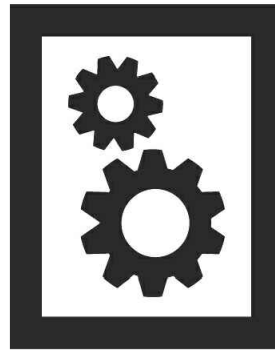

#### MANUALS

- ULTRASUITE MANUAL
- FTR ROOM-SIDE REPLACEABLE FILTER (RSR) QUICK START GUIDE
- URDC ULTRA DRIVER CABINET MANUAL
- UCA ULTRA COMPONENTS AND ACCESSORIES MANUAL
- HGWC HOSPITAL GRADE WELDED CEILING SYSTEM MANUAL



#### CATALOGUE / PERFORMANCE

- USA ULTRASUITE CATALOGUE
- USA ULTRASUITE PERFORMANCE
- USA ULTRASUITE PERFORMANCE (METRIC)

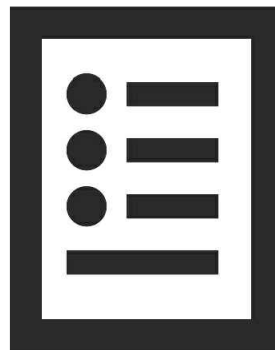

#### SPECIFICATIONS

- USA ULTRASUITE SPECIFICATIONS

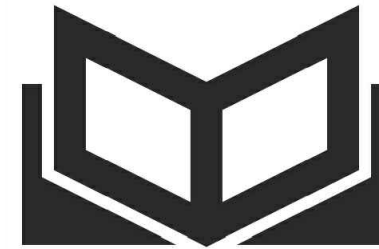

#### BROCHURES

- USA ULTRASUITE BROCHURE
- USA ULTRASUITE OPERATING ROOM HVAC DESIGN GUIDE
- USA ULTRASUITE PROJECT LIST
- USA ULTRASUITE CASE STUDY LIBRARY



#### SUBMITTALS

- UCA ULTRA COMPONENTS AND ACCESSORIES SUBMITTAL
- FTR REPLACEMENT FILTER SUBMITTAL
- HGWC HOSPITAL GRADE WELDED CEILING SYSTEM SUBMITTAL

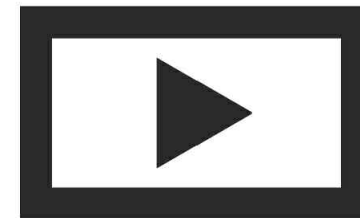

#### VIDEOS

- USA ULTRASUITE LAUNCH VIDEO
- USA ULTRASUITE INSTALLATION TIME LAPSE VIDEO
- USA ULTRASUITE SMOKE TEST VIDEO
- USA ULTRASUITE IN BAYLOR SCOTT & WHITE MEDICAL CENTER TESTIMONIAL
- HEPA FILTER REPLACEMENT (USA AND UFFU) VIDEO
- USA ULTRASUITE SEISMIC TESTING



FOR MORE INFORMATION ON PRICE ULTRASUITE SYSTEMS, VISIT [PRICEINDUSTRIES.COM](http://PRICEINDUSTRIES.COM)

**price** | **CRITICAL ENVIRONMENTS**

Project:

276328

Revision: 0

01-12-2024